

# "Things Don't Always Seem as They Appear"

## Assembling the Quilt

1. Sew the blocks together into rows, referring to the quilt layout photo. Join the rows together to complete the quilt center.
2. Cut two red 1 1/2" strips in half and join to the four remaining strips. Measure the sides of your quilt, cut two red border strips to this measurement and attach. Measure the quilt with these added borders and cut two additional strips for the top and bottom borders.
3. Repeat this process to attach the outer black tossed cards border.
4. Quilt as desired and bind with the 2 1/4" strips, using your favorite method.



**Barbara Campbell is a quilt and pattern designer from Pine Brook, NJ. You can see more of Barbara's work at [www.loveinstitches.com](http://www.loveinstitches.com).**

Be sure to visit [www.windhamfabrics.com](http://www.windhamfabrics.com) to see the complete collection and to download this and other Free Projects

WINDHAM FABRICS

812 Jersey Ave ~ Jersey City, NJ 07310 ~ 201.659.0444 ~ FAX: 201.659.9719 ~ [info@windhamfabrics.com](mailto:info@windhamfabrics.com)

# "Things Don't Always Seem as They Appear"

Designed by Barbara Campbell

Featuring fabric from the Adventures in Wonderland Collection  
by Whistler Studios



WINDHAM FABRICS 

# "Things Don't Always Seem as They Appear"

Designed by Barbara Campbell

Featuring fabric from the Adventures in Wonderland Collection

by Whistler Studios

Quilt Size: 50" X 50"

Block Size: 8"

## Materials & Cutting Chart:

Yardage	SKU #	Description	Cutting Instructions
1-1/4 yard	30857-X	Multi Focus Fabric	Use the plastic 6 1/8" square template to identify and cut twelve motifs from the fabric, positioning the template diagonally. (Block #1 centers)
3/8 yard	30852-1	Blue Stripe	Cut twelve 5" squares; recut diagonally once (Block #1 corners)
3/8 yard	30852-2	Green Stripe	Cut twelve 5" squares; recut diagonally once for (Block #1 corners)
3/8 yard	30854-3	Black Check	Cut four 8 1/2" squares (Block #2)
5/8 yard	30853-6	White Card Men	Cut nine 8 1/2" squares (Block #2)
1 yard	30850-3	Toss characters/Blk	Cut fifty-two curved pieces from the fused print
3/4 yard	30855-4	Red tonal	Cut six 1 1/2" strips (inner border); cut six 2 1/4" strips (binding)
1 yard	30851-3	Black tossed cards	Cut six 4 1/2" strips (outer border)
3 1/2 yds	30850-2	Green Back Fabric	Cut and piece to measure 55" square
3 1/2 yds		12" wide Paper-Backed Fusible Web	Trace 52 curved pieces on the paper side of the fusible web, leaving at least 1/2" between pieces
55" x 55"		Batting	
		Template Plastic	Cut one 6 1/8" square to use in fussy-cutting focus fabric for Block #1; cut one curved template for Block #2
		Fine Line Permanent Marker	For tracing shapes on template plastic, marking squares on the right side of the focus fabric and also on the paper side of fusible web

## Sewing Instructions:

### Block #1



1. Fold the 6 1/8" focus fabric squares in half to find the middle of each side. Fold the green triangles in half on the long edge to find the center. Match the center of the triangle with one side of the square and stitch in place. Repeat to sew the opposite side. Sew the other two triangles on the final sides in the same fashion. Press and trim the blocks to measure 8 1/2" if necessary. Make six green blocks.
2. Repeat this process to make six blue blocks.

### Block #2



1. Fuse the fifty-two curved pieces that you traced on the paper-backed fusible web to the wrong side of the black tossed character fabric. Loosely cut the curved pieces apart, leaving at least 1/4" around each piece. Cut each piece carefully on the drawn line.
2. Peel the paper backing from four of the curved pieces and position them on one black checked square as shown in the illustration. Fuse in place.
3. Repeat to make a total of four black checked blocks and nine white card men blocks.
4. Stitch the curved edges of these blocks with a blanket stitch, zigzag or raw edge appliqué stitch by machine either before stitching the blocks together or as part of the quilting process. This will secure all fused curved edges. (Ignore this step if you have added a seam allowance to the curved edge of these pieces and hand or machine appliquéd them in place.)

# *"Things Don't Always Seem as They Appear"*

## TEMPLATES

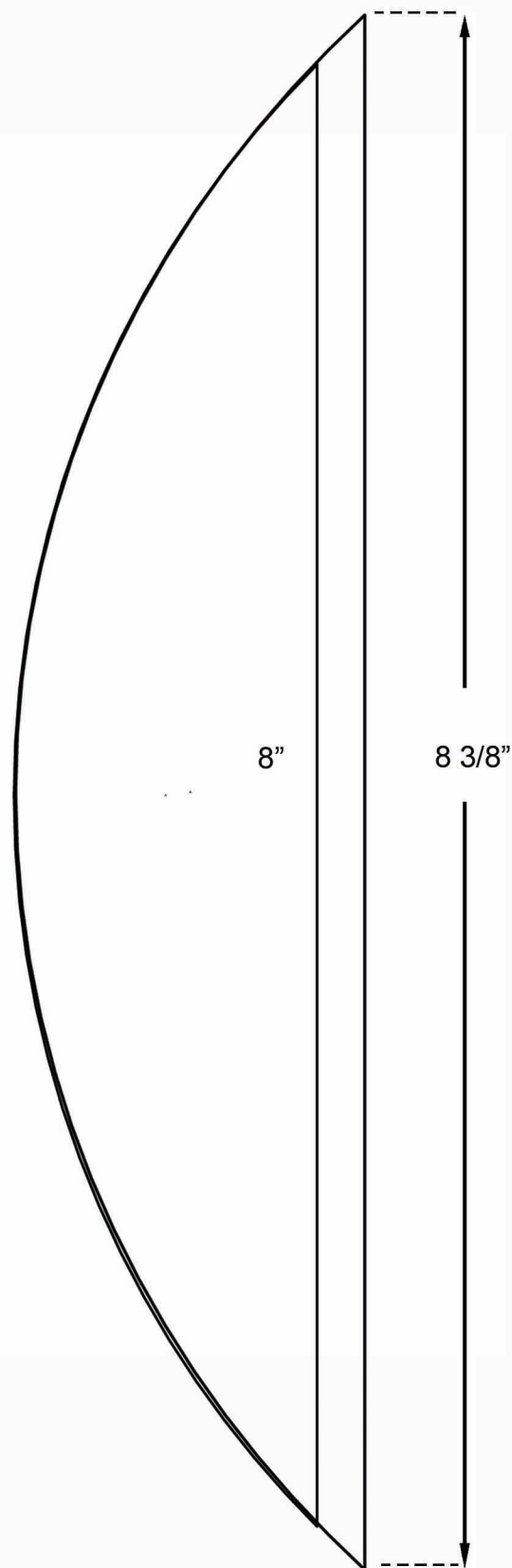
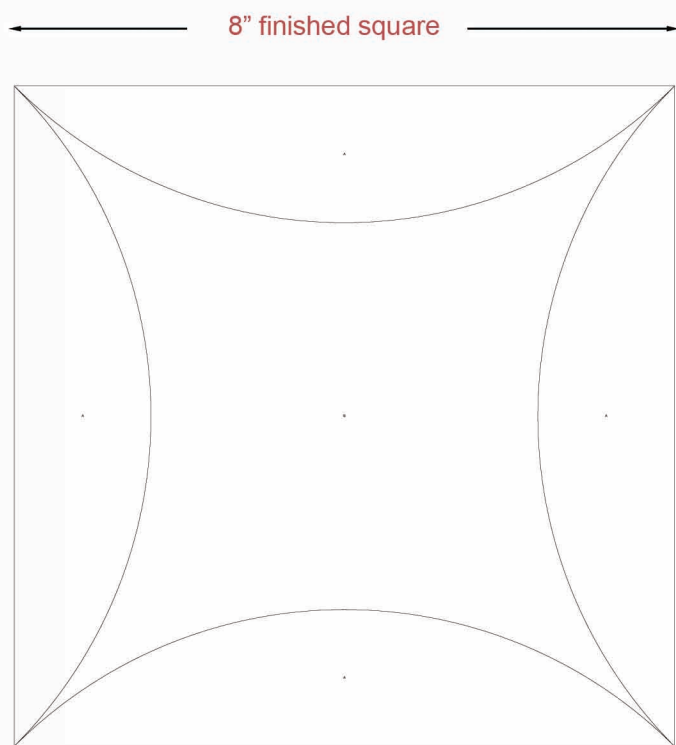

Actual size of template:  $8 \frac{3}{8}$ " long  
Check as copies do not always translate the same on  
each printer  
Add  $\frac{1}{4}$ " seam allowance to curved side if using hand  
appliqué method instead of fusing