

# In Motion

designed by Melissa Marie Collins

featuring the In Motion fabric collection by Melissa Marie Collins

QUILT SIZE: 73" x 89"











FREE  
PROJECT

THIS IS A DIGITAL REPRESENTATION OF THE QUILT TOP, FABRIC MAY VARY.

**PLEASE NOTE:** BEFORE MAKING YOUR PROJECT, CHECK FOR ANY PATTERN UPDATES AT [WINDHAMFABRICS.COM](http://WINDHAMFABRICS.COM)'S FREE PROJECTS SECTION.



## In Motion

KEY	FABRIC	SKU	YD	CUTTING INSTRUCTIONS
A		53749D-12 cloud	4	<ul style="list-style-type: none"> <li>• (4) 32-1/2" x 37-1/2" rectangles.</li> </ul>
B		53748D-3 leaf	3/8	<ul style="list-style-type: none"> <li>• (2) 4-1/2 x WOF strips. Sub-cut (8) 4-1/2" x 6-1/2" strips</li> </ul>
C		53750D-15 treetop	3/8	<ul style="list-style-type: none"> <li>• (2) 4-1/2 x WOF strips. Sub-cut (8) 4-1/2" x 6-1/2" strips</li> </ul>
D		53748D-6 charcoal	3-1/4	<ul style="list-style-type: none"> <li>• See instructions to cut (1) Tree Trunk, (1) Branch 1, (1) Branch 2, (1) Branch 3 and (1) Branch 4.</li> </ul>
E		53753D-X multi	2	<p><b>NOTE: Attach fusible web to fabric before cutting leaves.</b></p> <ul style="list-style-type: none"> <li>• Fussy cut (55) Leaves.</li> </ul>
F		53749D-10 sky	5/8	<ul style="list-style-type: none"> <li>• (4) 2" x WOF strips. Sew the strips together with diagonal seams and cut (2) 2" x 80-1/2" strips.</li> <li>• (4) 2" x WOF strips. Sew the strips together with diagonal seams and cut (2) 2" x 67-1/2" strips.</li> </ul>
G		53748D-5 violet	1	<ul style="list-style-type: none"> <li>• (4) 3-1/2" x WOF strips. Sew the strips together with diagonal seams and cut (2) 3-1/2" x 83-1/2" strips.</li> <li>• (4) 3-1/2" x WOF strips. Sew the strips together with diagonal seams and cut (2) 3-1/2" x 73-1/2" strips.</li> </ul>
H		53750D-16 midnight	2/3	<ul style="list-style-type: none"> <li>• (8) 2-1/2" x WOF strips for the binding.</li> </ul>
		Backing	5-1/2	<ul style="list-style-type: none"> <li>• (2) 97" x WOF strips. Sew the strips together and trim to 81" x 97" to make the pieced back.</li> </ul>
		You will also need:		<ul style="list-style-type: none"> <li>• Batting 81" x 97"</li> </ul>

Project Disclaimer: Every effort has been made to ensure that all projects are error free. All the information is presented in good faith, however, no warranty can be given nor results guaranteed. Therefore, we assume no responsibility nor damages that may occur when referring to this pattern. When errors are brought to our attention, we make every effort to correct and post a revision as soon as possible. We suggest you check windhamfabrics.com for pattern updates and to test the pattern prior to making the project. Test templates first, before cutting all the pieces. Free projects are not for resale.





# In Motion

## Quilt Top Assembly

*(Refer to the Quilt Diagram while assembling the quilt top.)*

9. Sew (1) 2" x 80-1/2" **F** strip to each side of the **Center Block**. Sew (1) 2" x 67-1/2" **F** strip to the top and to the bottom of the **Center Block**.

10. Sew (1) 3-1/2" x 83-1/2" **G** strip to each side of the **Center Block**. Sew (1) 3-1/2" x 73-1/2" **G** strip to the top and to the bottom of the **Center Block** to make the quilt top.

## Finishing

11. Layer and quilt as desired.

12. Sew the (8) **H** 2-1/2" x WOF strips together end-to-end with 45-degree seams to make the binding. Fold this long strip in half lengthwise with wrong sides together and press.

13. Bind as desired.

SIZE: 73" X 89"

Quilt Diagram

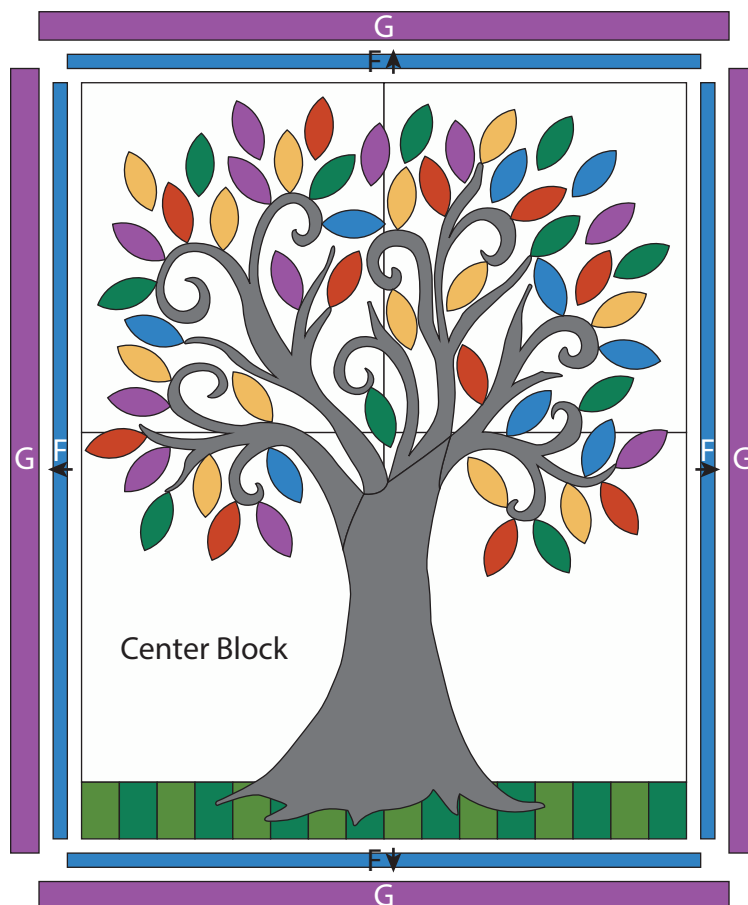





# In Motion

## Template Assembly Diagrams

**Note:** Templates have been reversed for fusible applique.

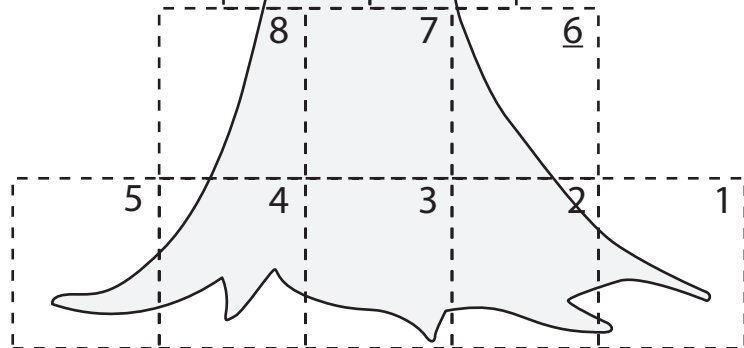
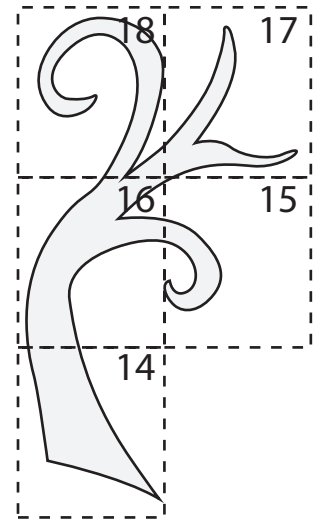
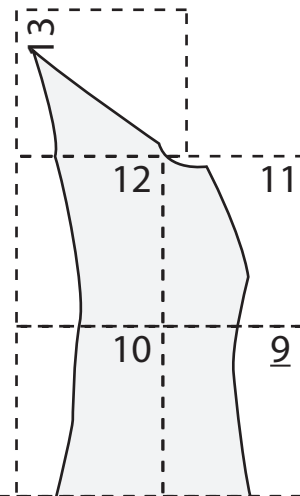
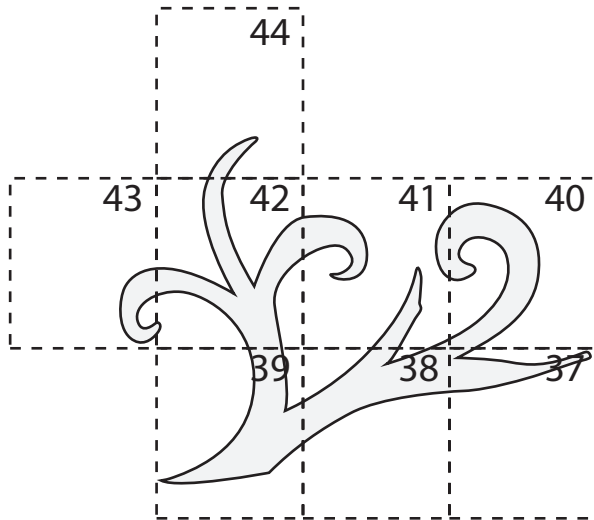
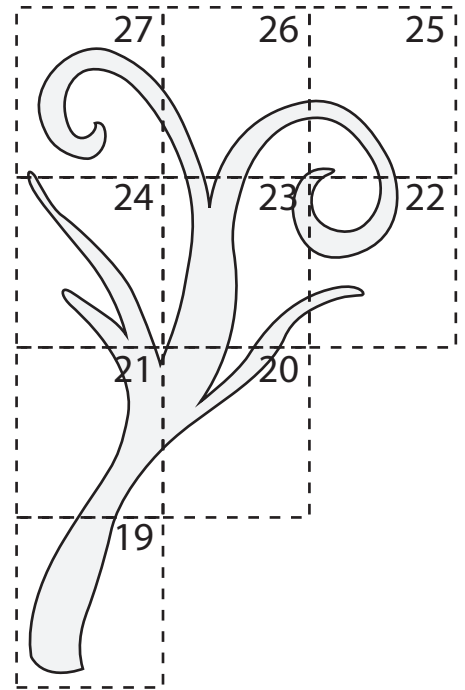
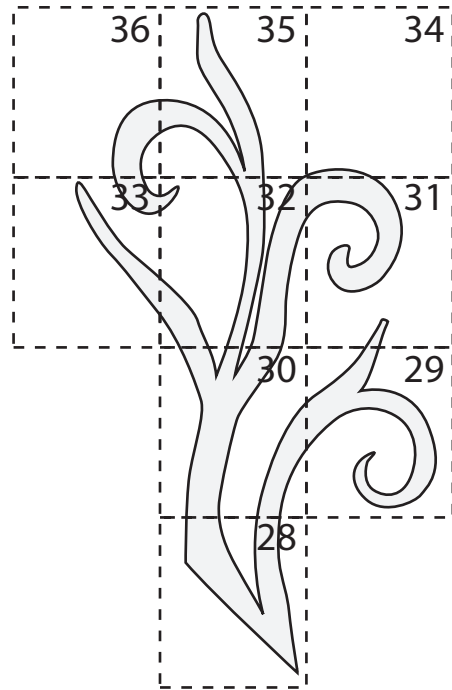



# In Motion

Template - 1

1

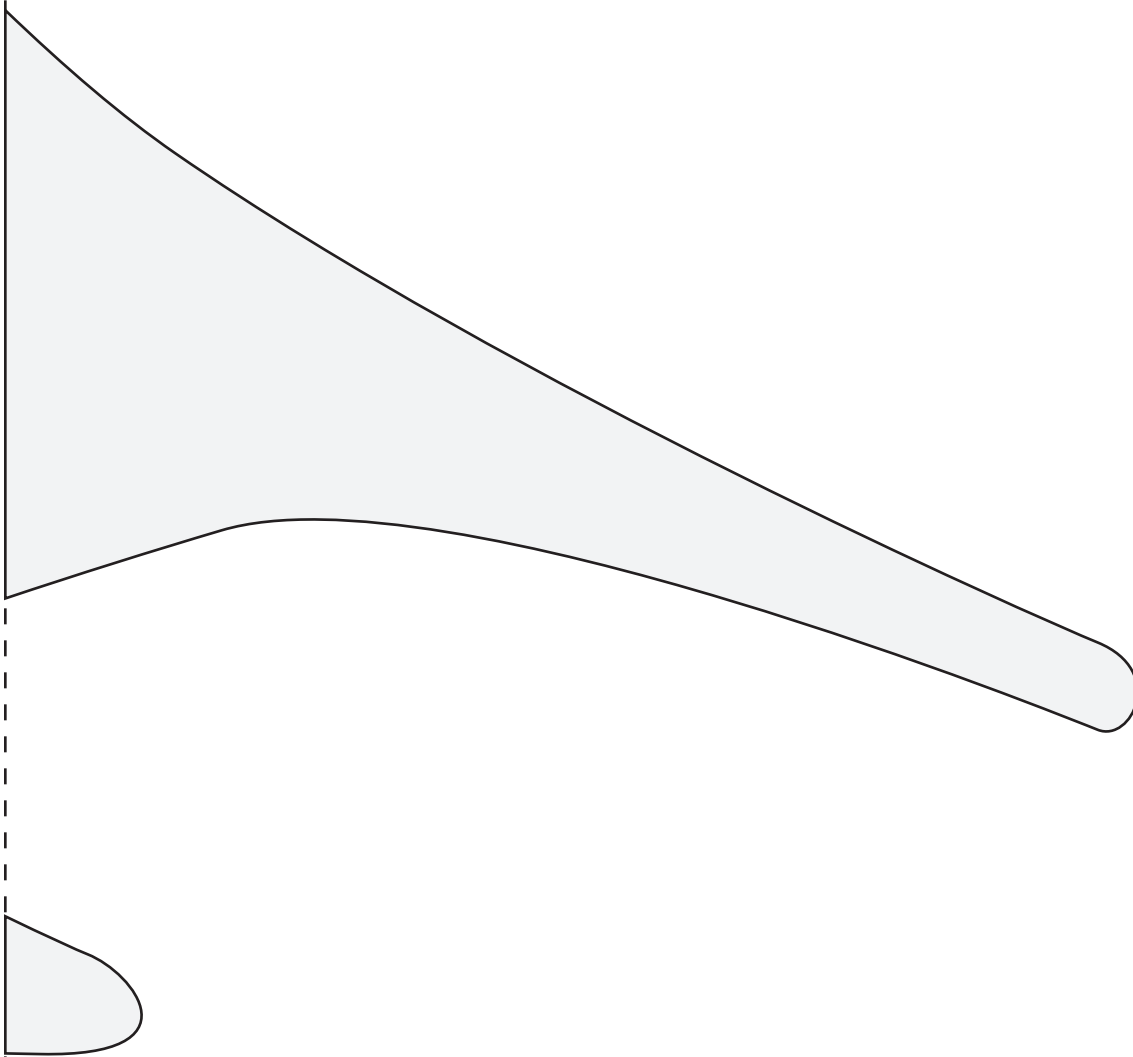



# In Motion

Template - 2

2

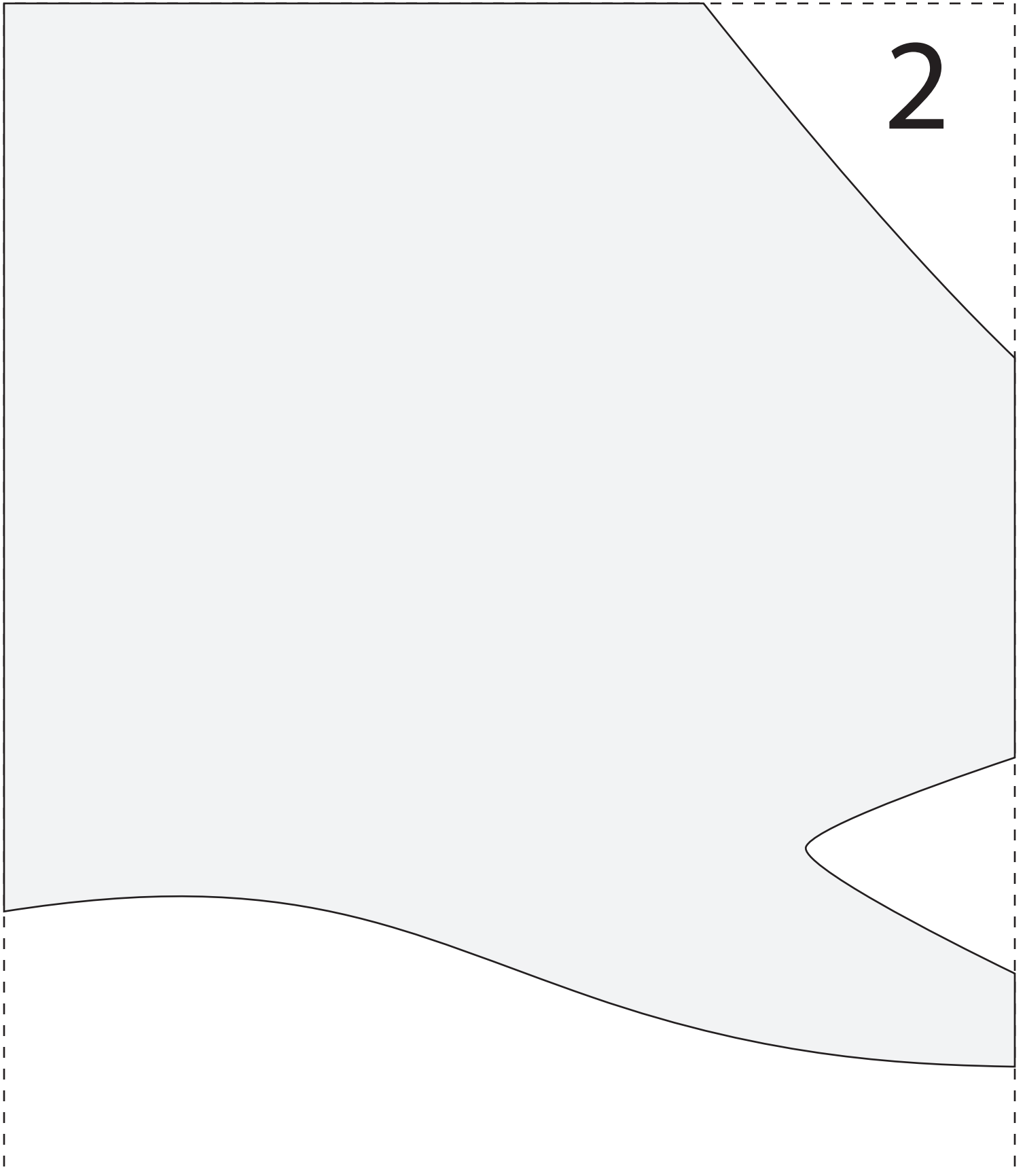



# In Motion

Template - 3

3

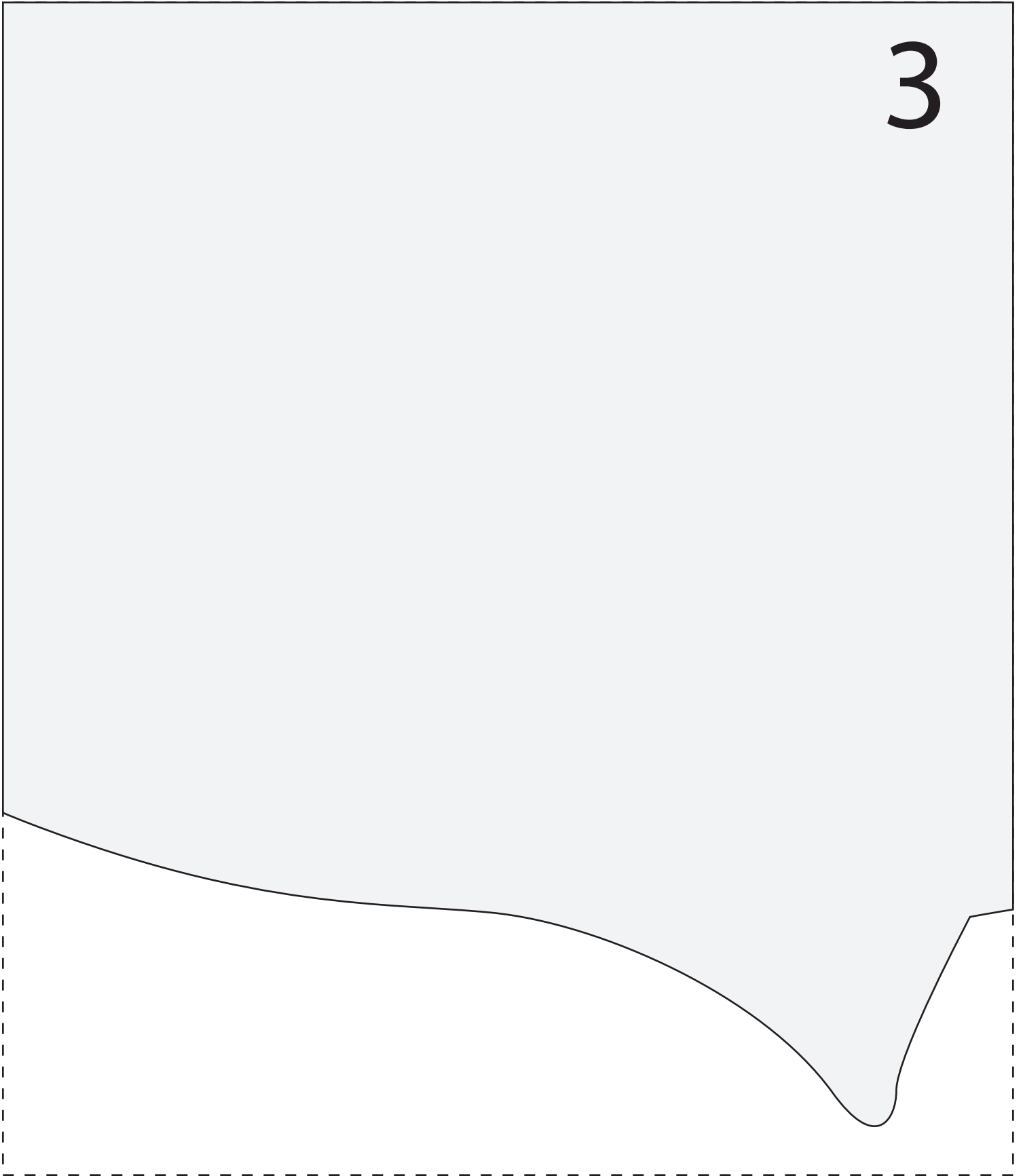





# In Motion

Template - 4

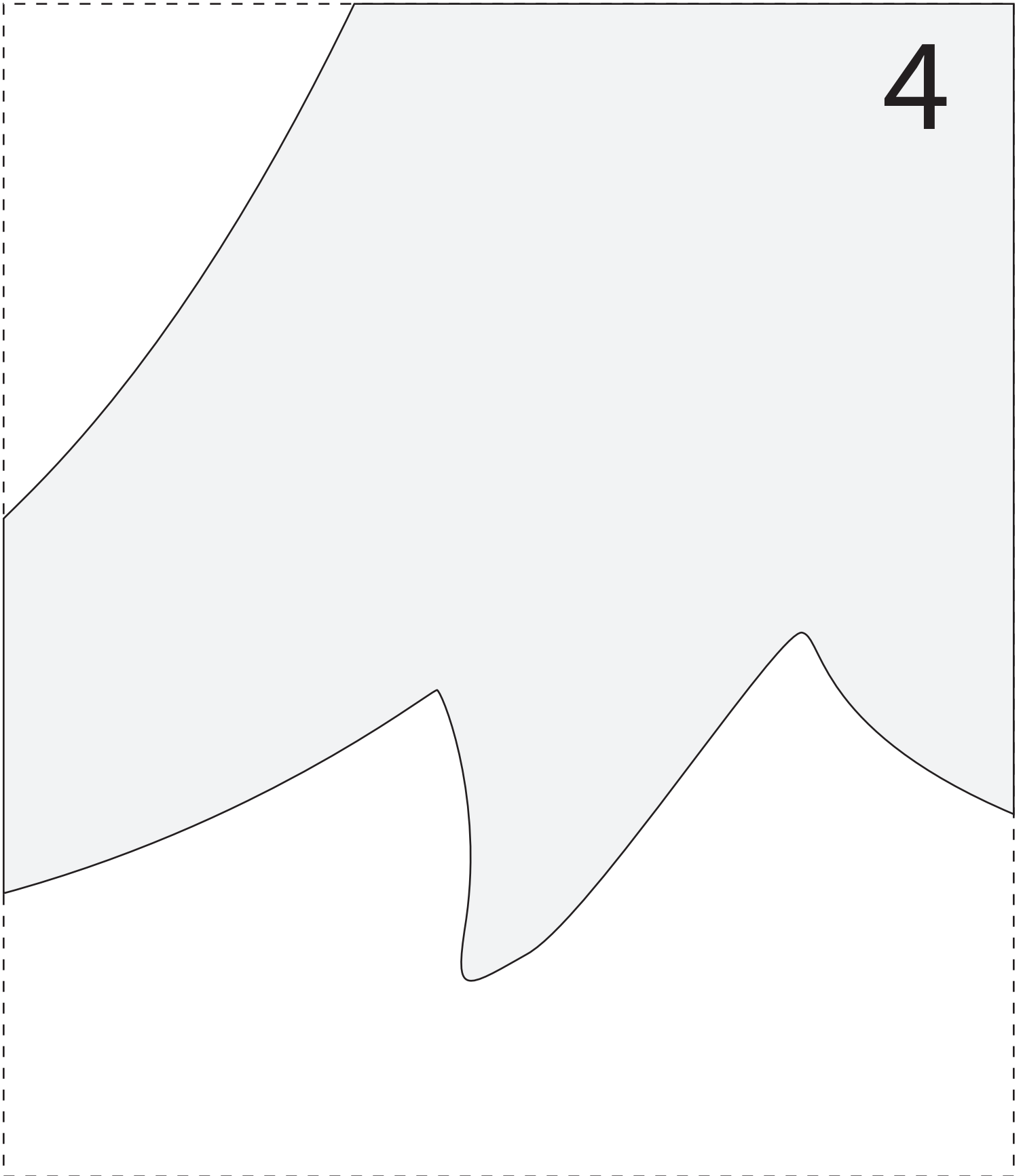



# In Motion

Template - 5

5





# In Motion

Template - 6

6

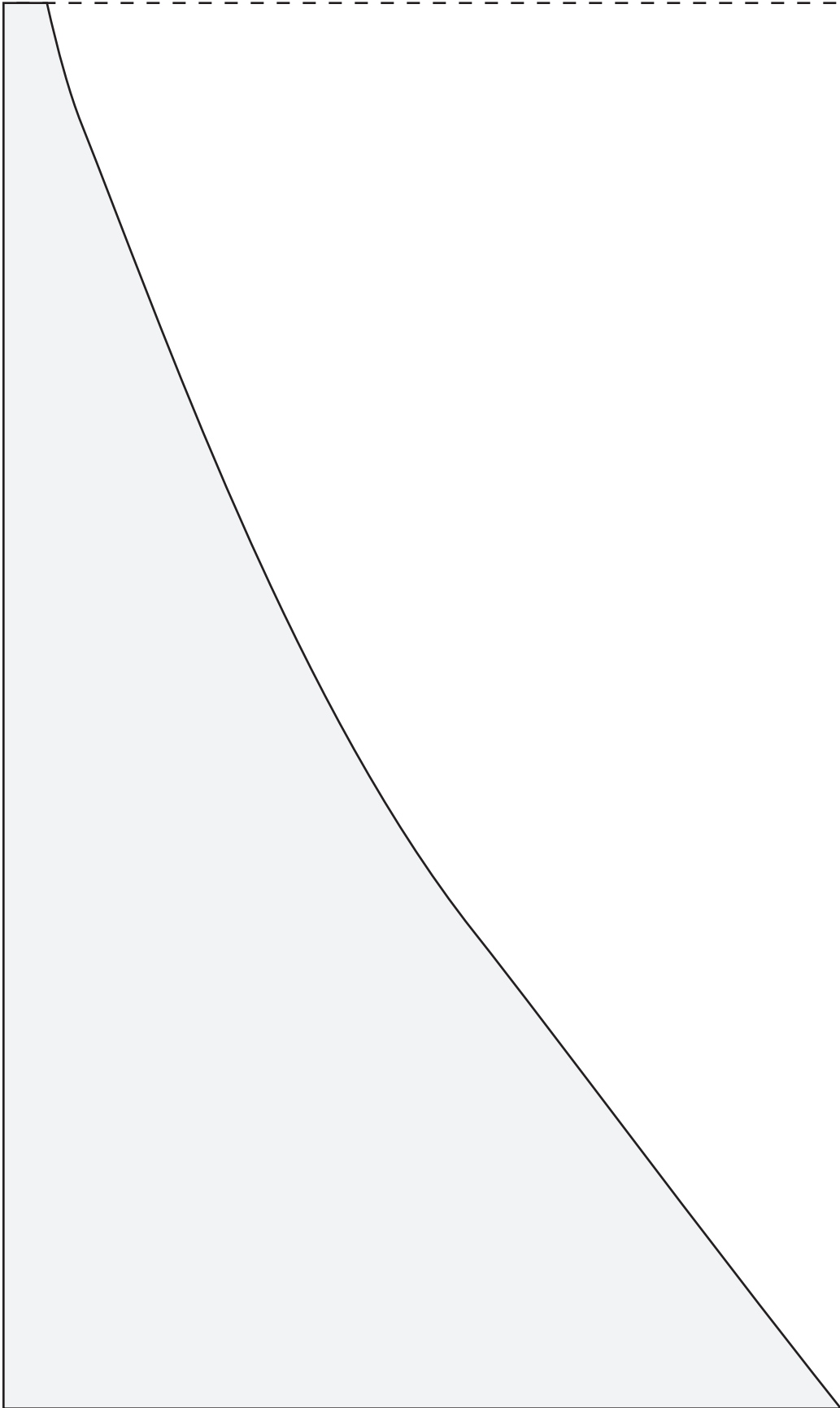



# In Motion

Template - 7

7





# In Motion

Template - 8

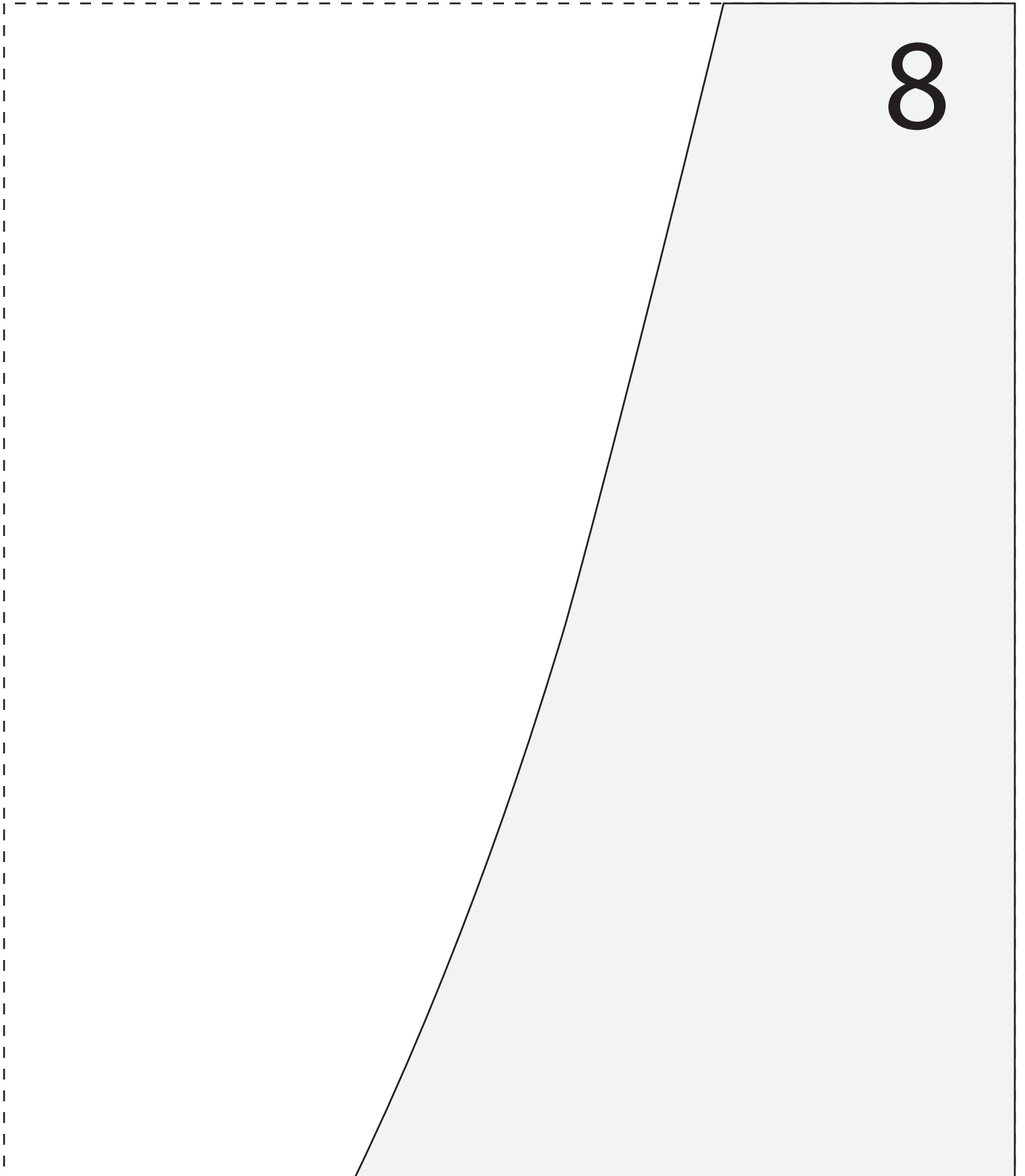



# In Motion

Template - 9

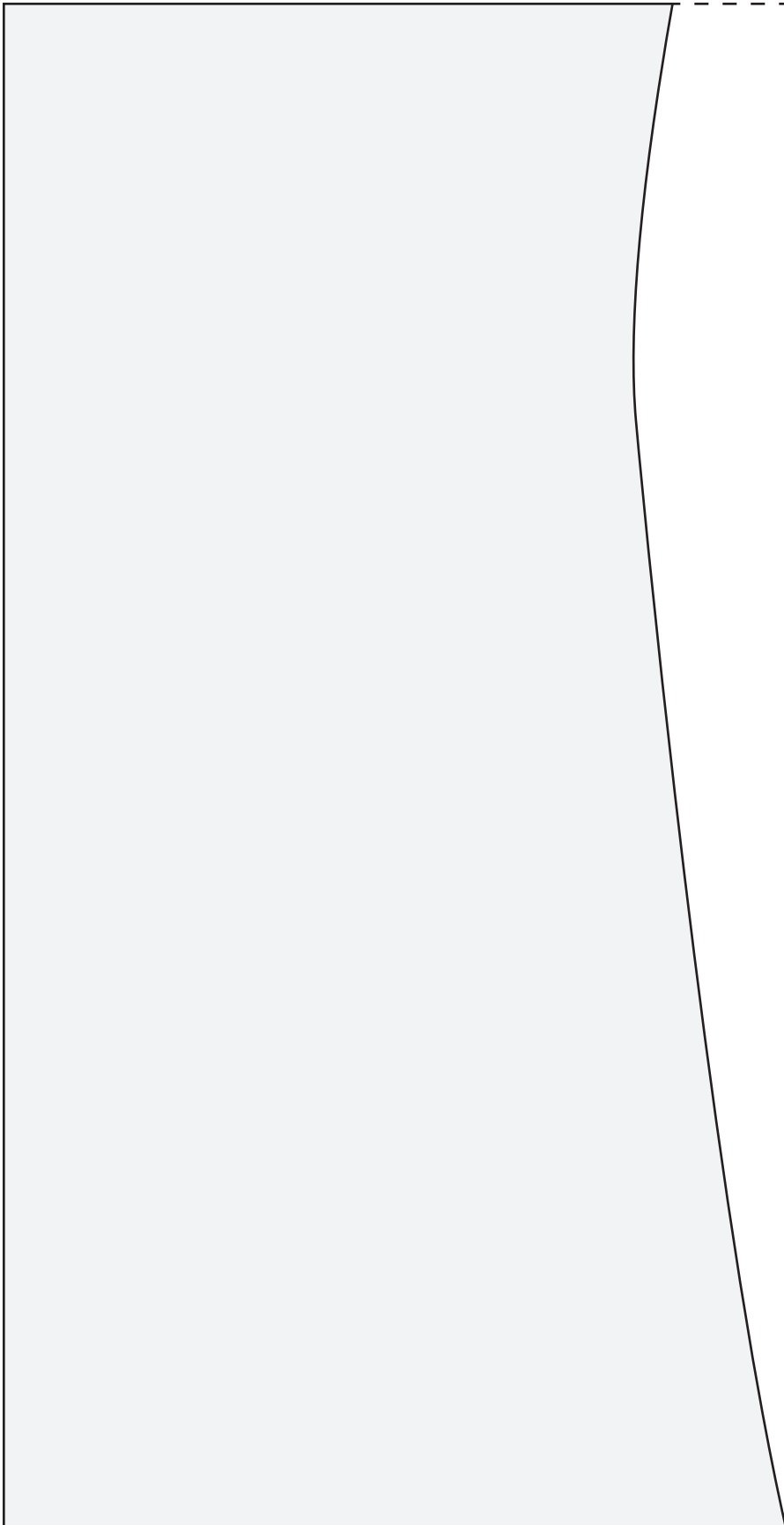

9



# In Motion

Template - 10

10

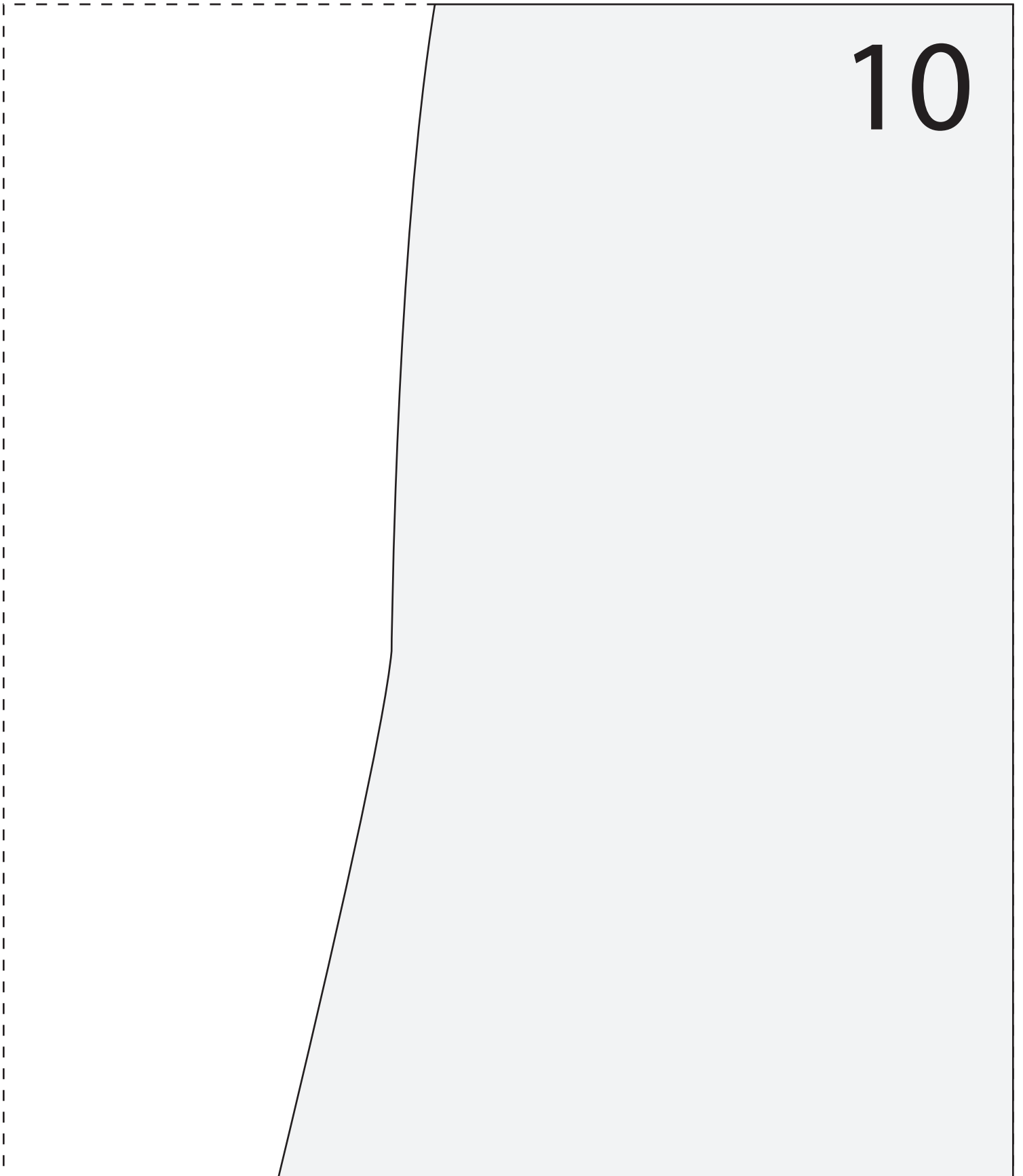



# In Motion

Template - 11

11

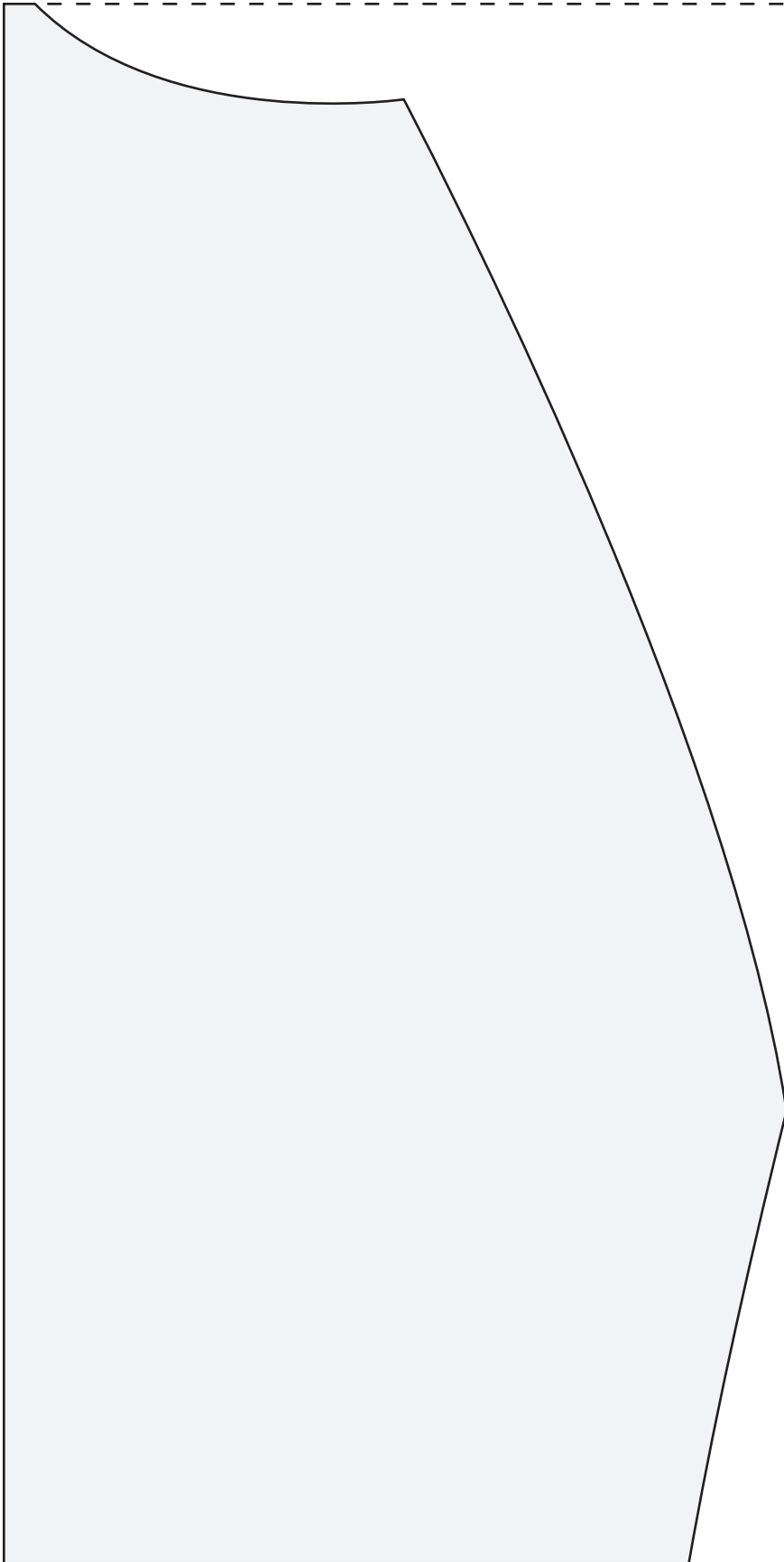





# In Motion

Template - 12

12

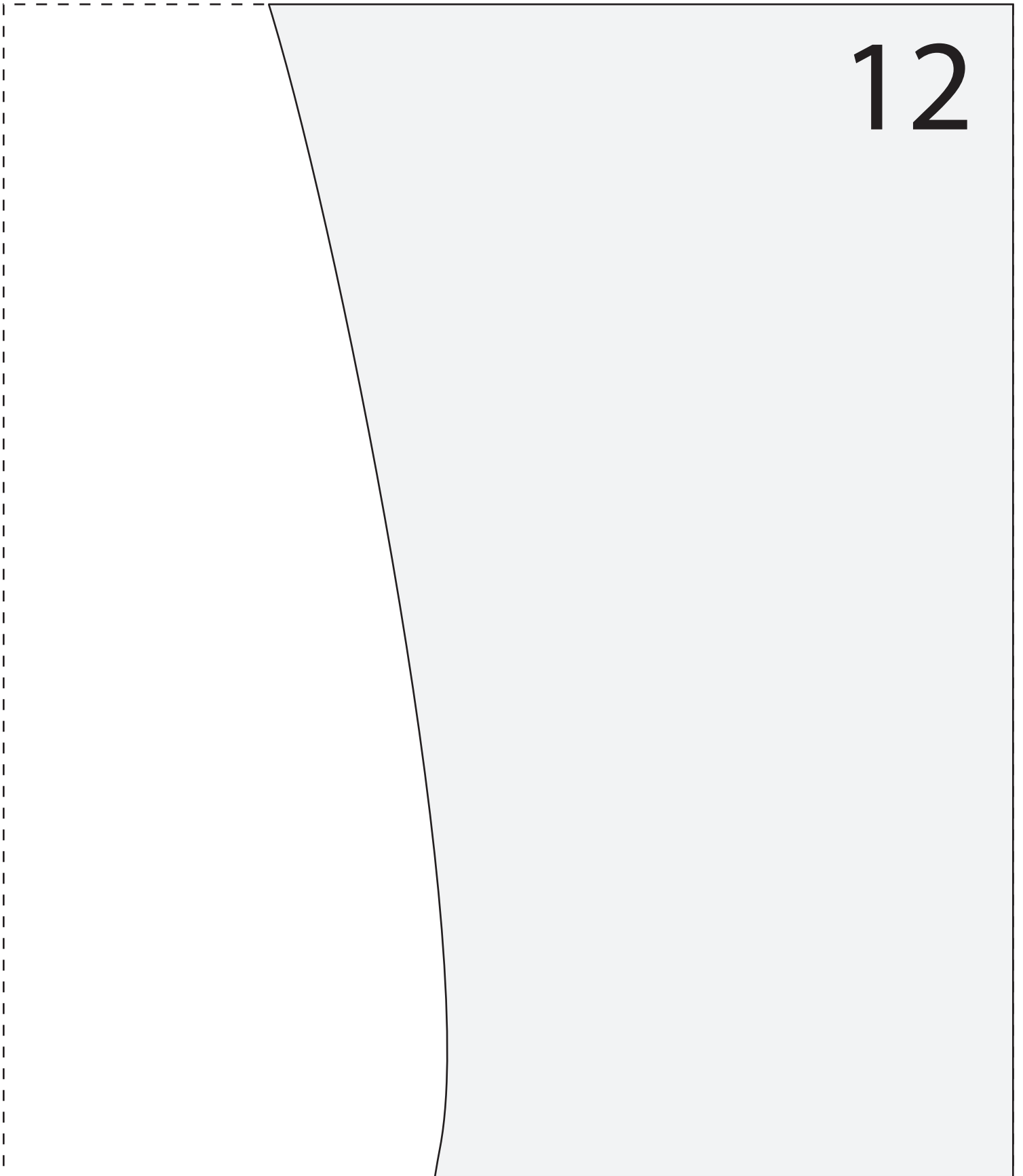



# In Motion

Template - 13

13

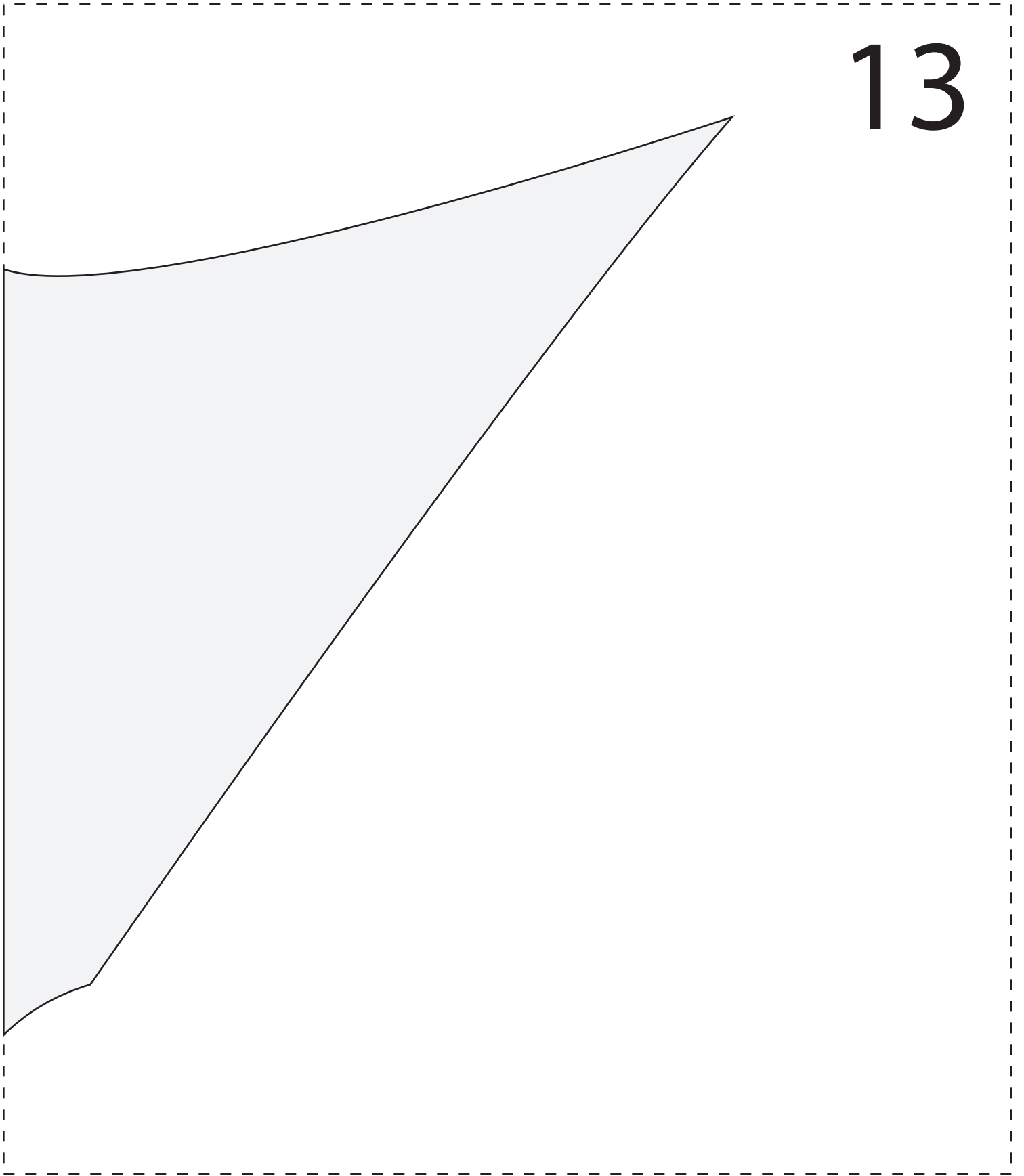



# In Motion

Template - 14

14

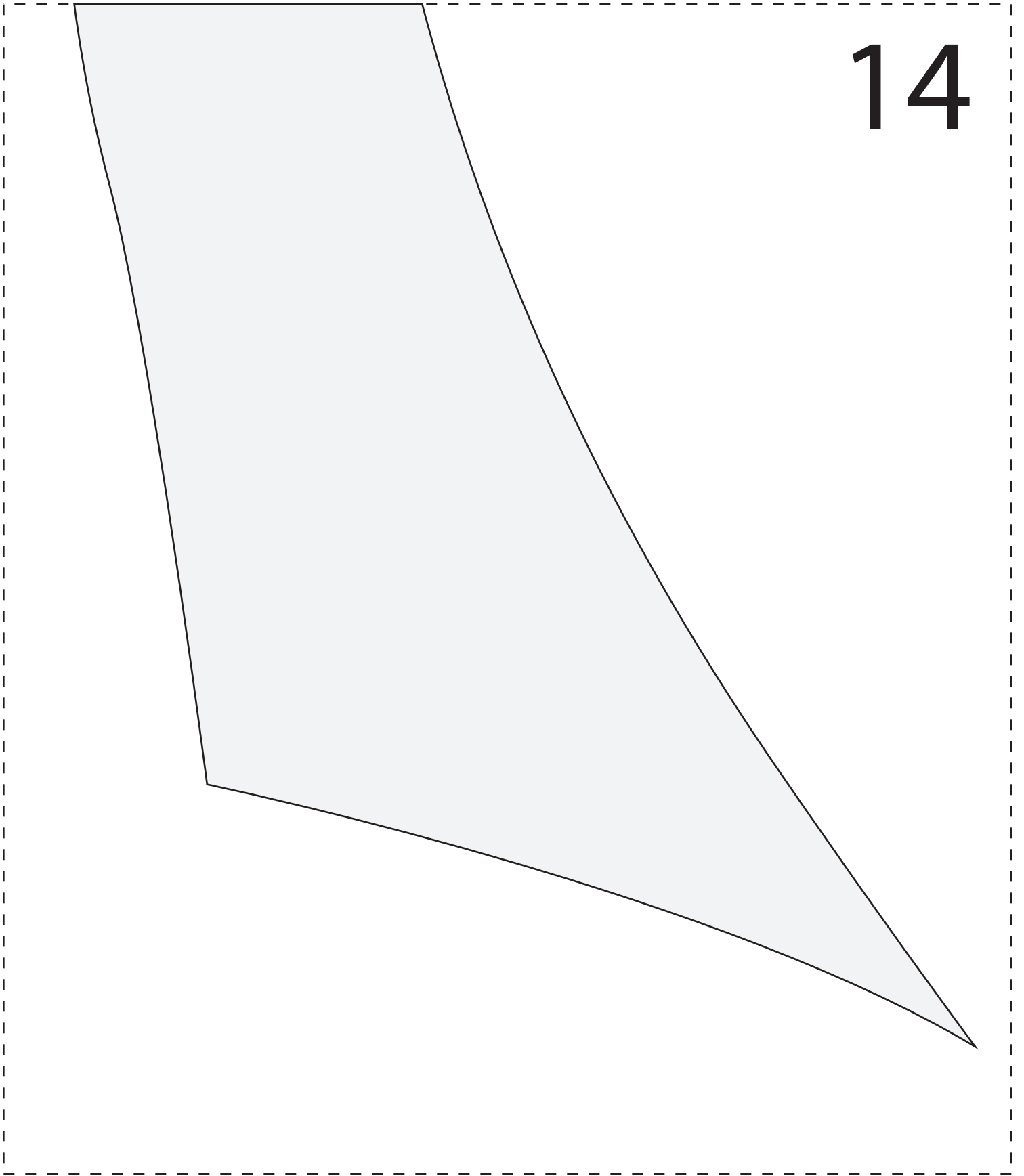



# In Motion

Template - 15

15

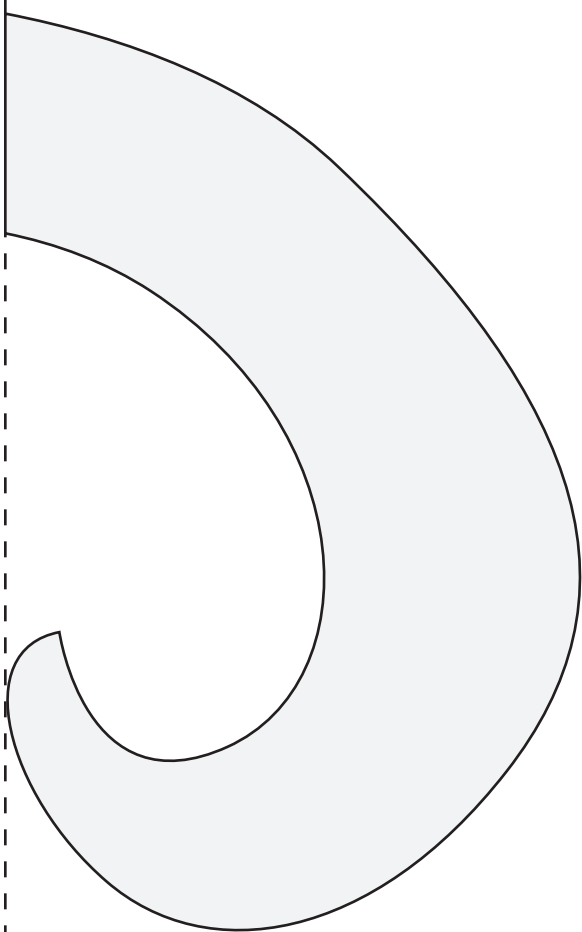





# In Motion

Template - 16

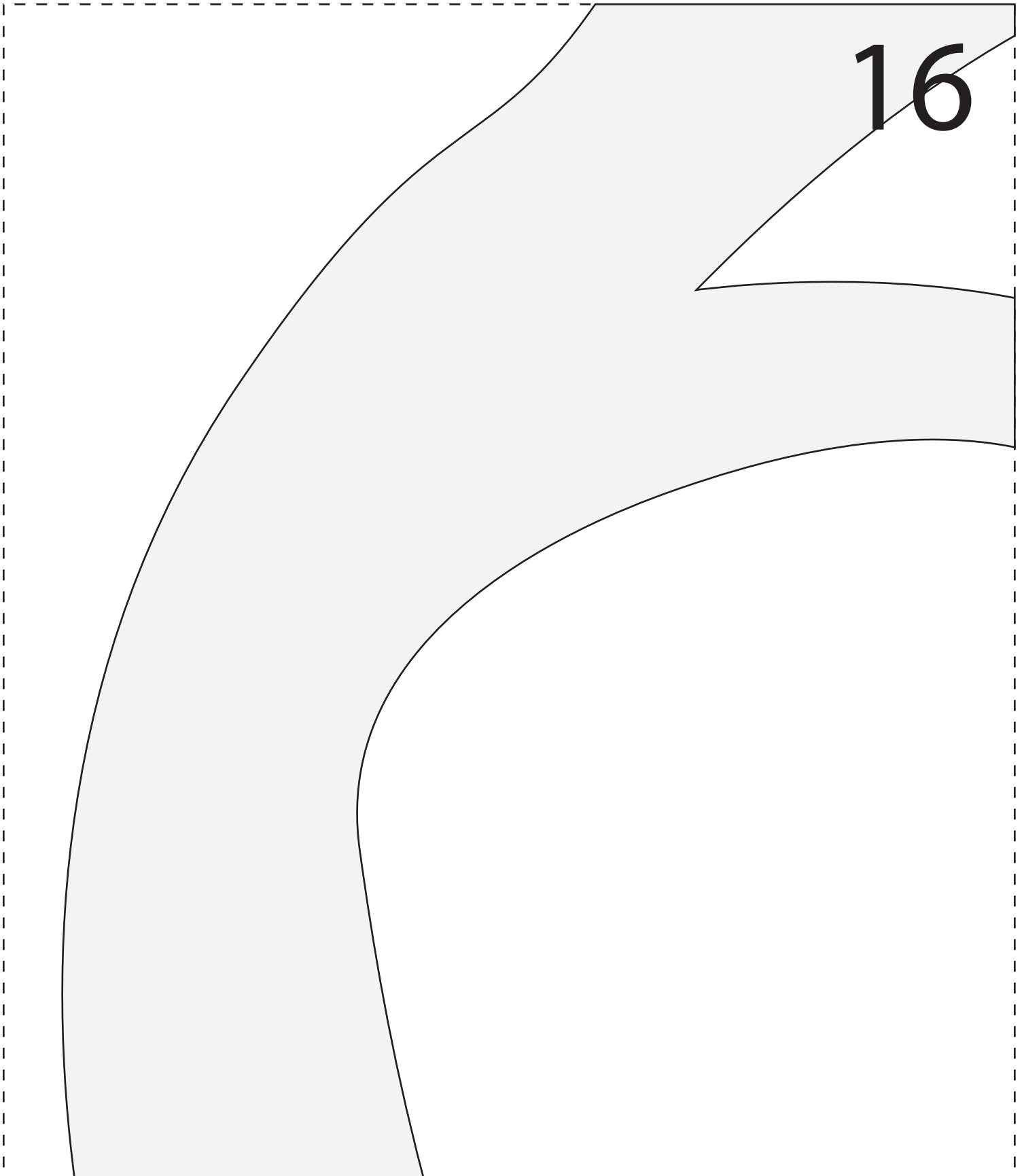



# In Motion

Template - 17

17

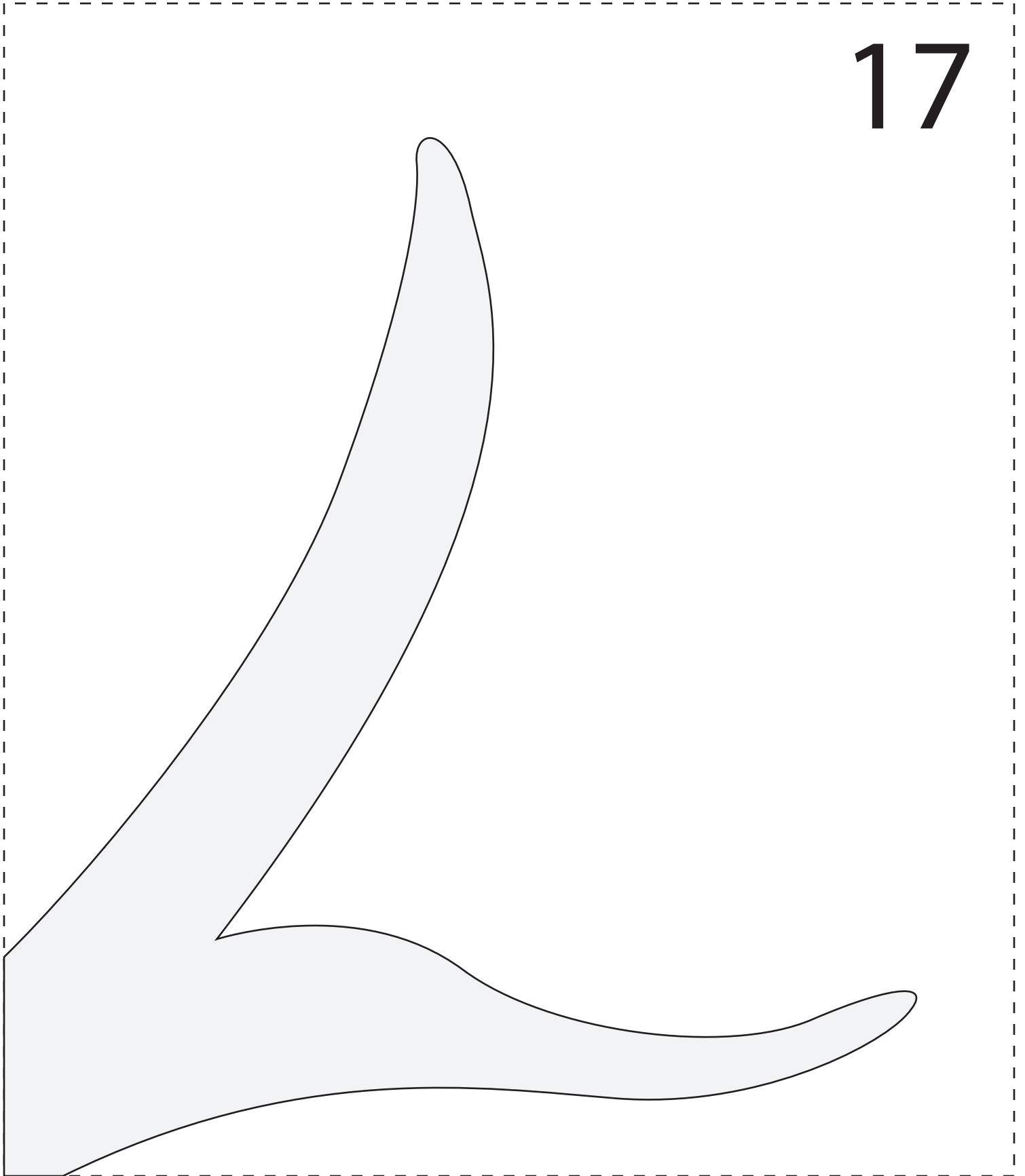



# In Motion

Template - 18

18

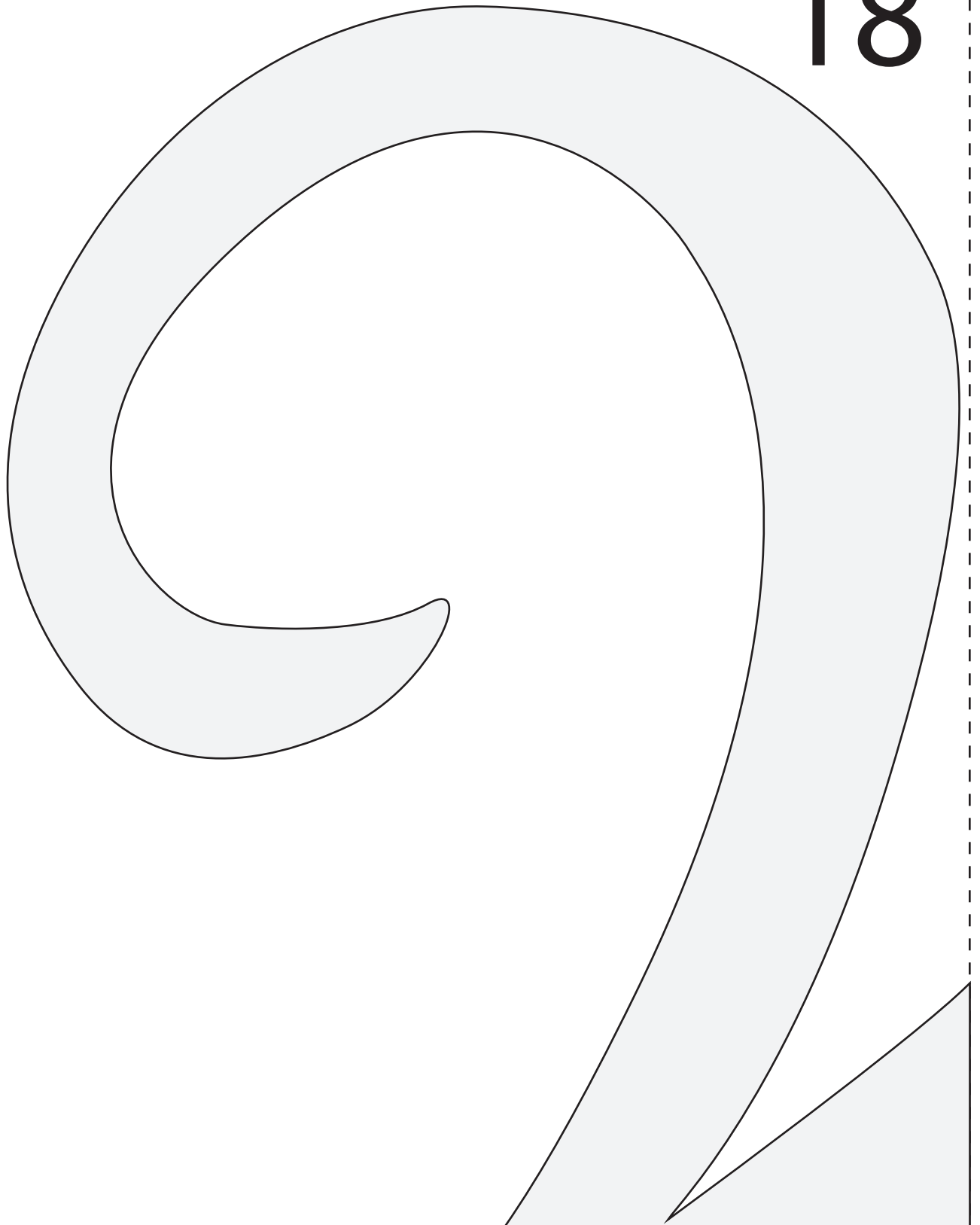



# In Motion

Template - 19

19

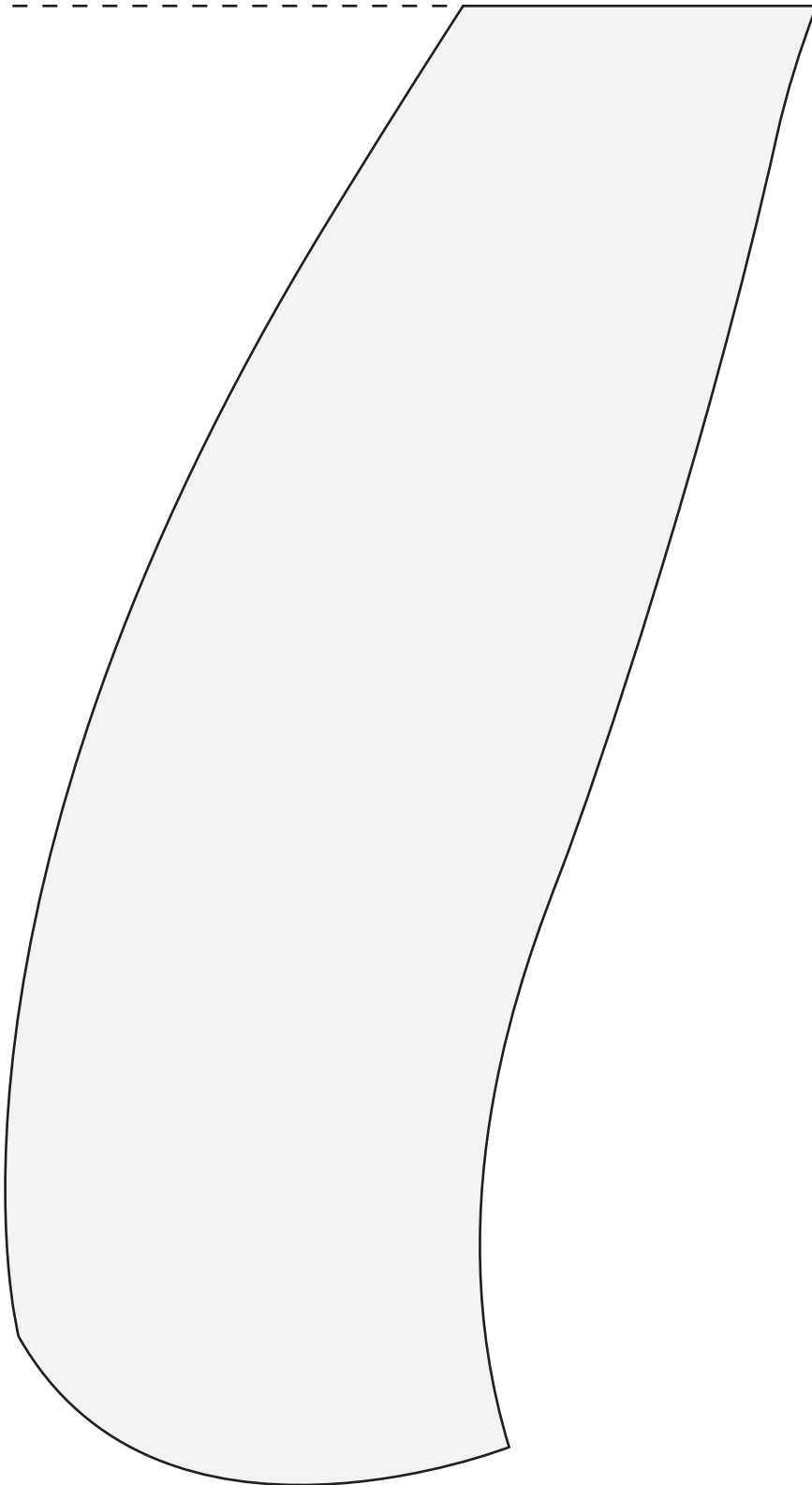



# In Motion

Template - 20

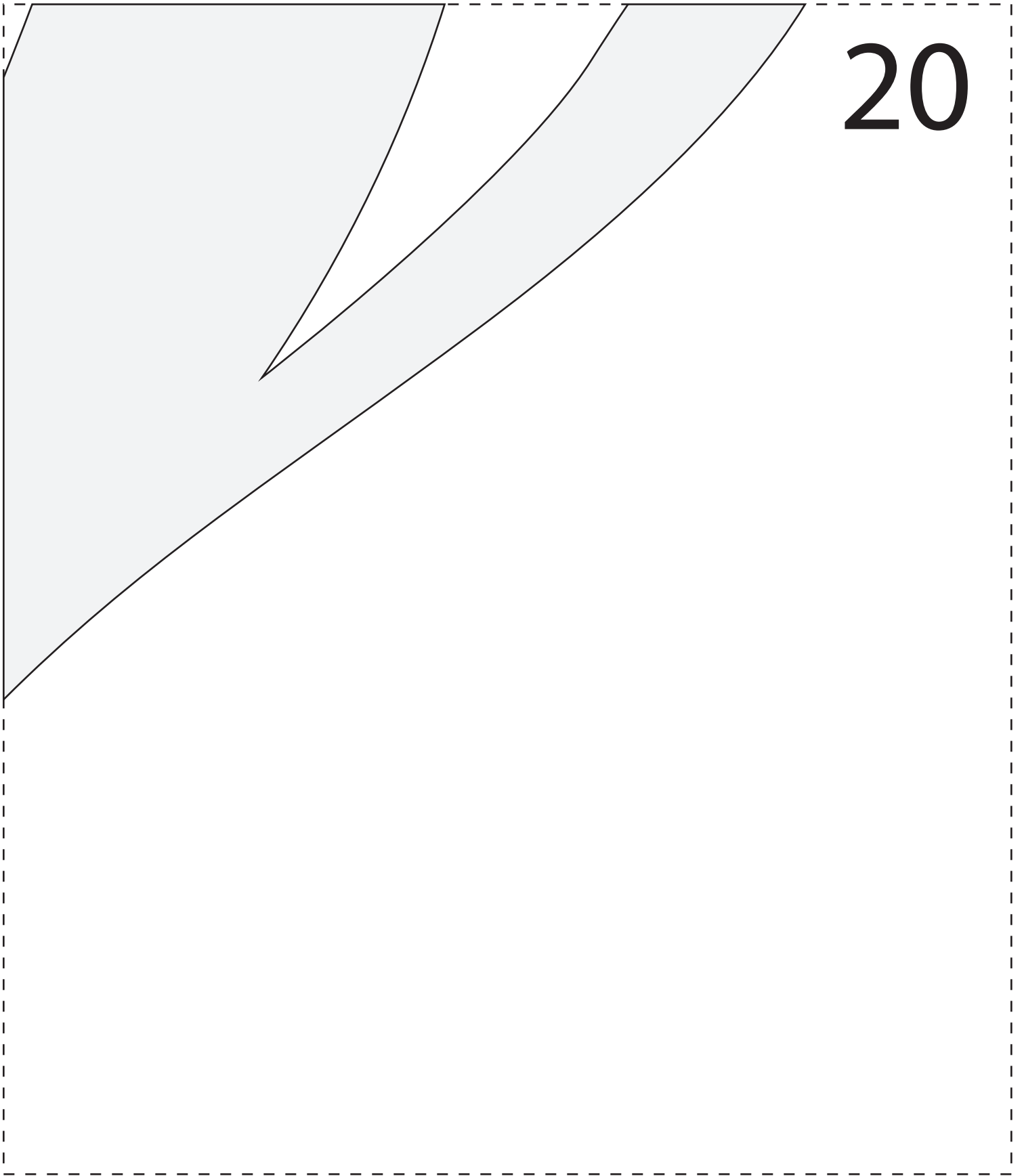

20



# In Motion

Template - 21



21



# In Motion

Template - 22

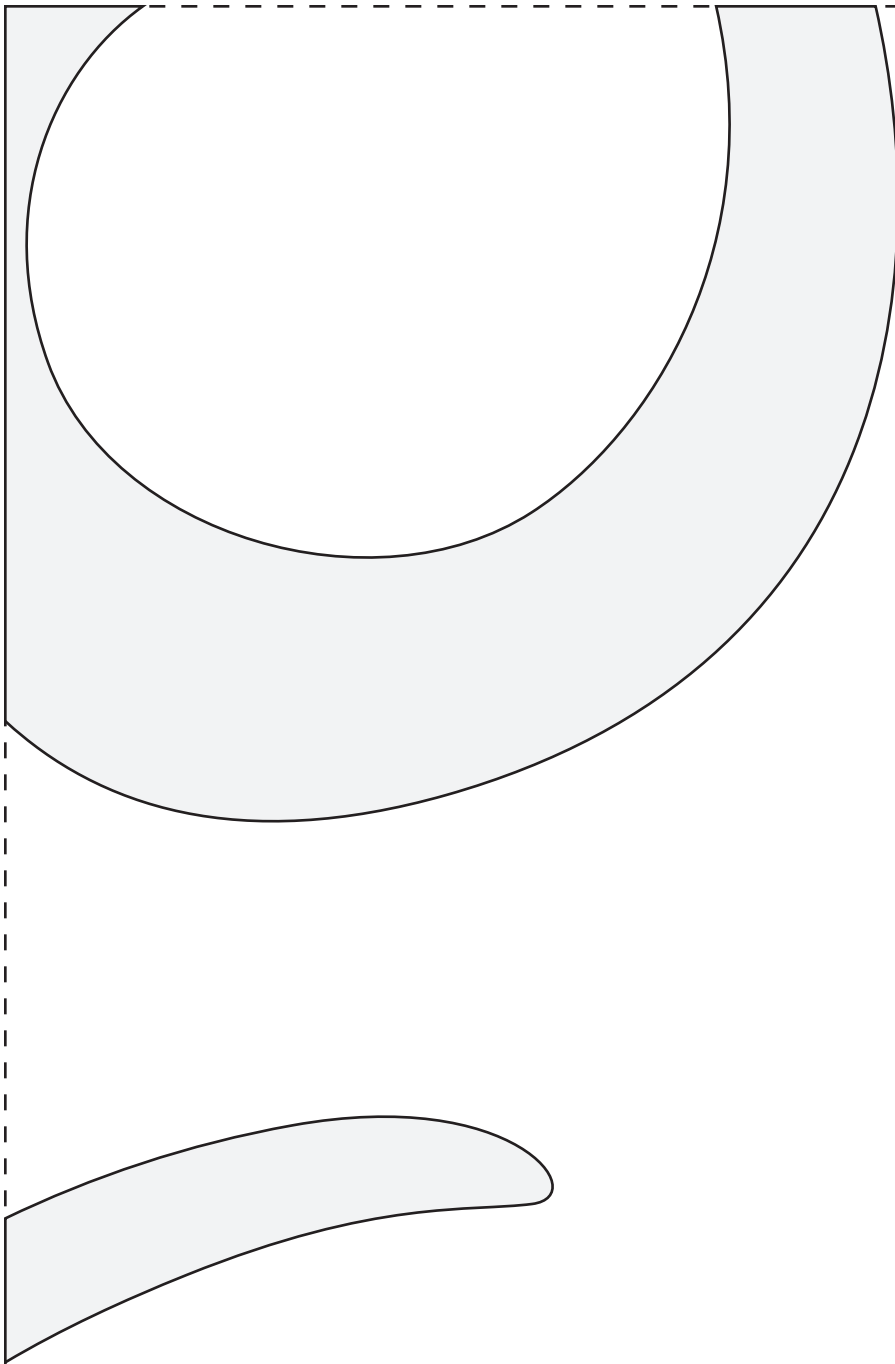

# 22



# In Motion

Template - 23

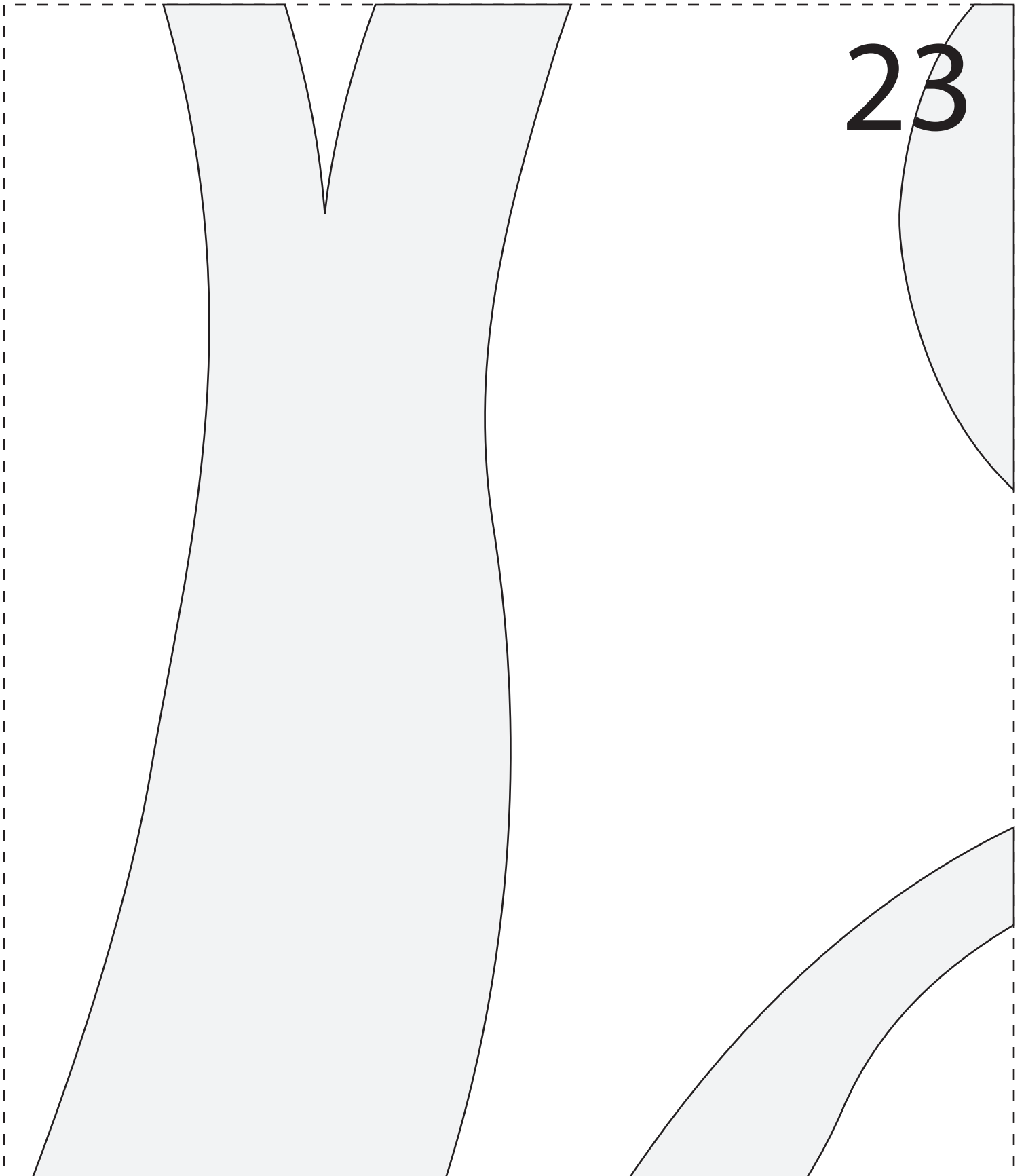





# In Motion

Template - 24

24

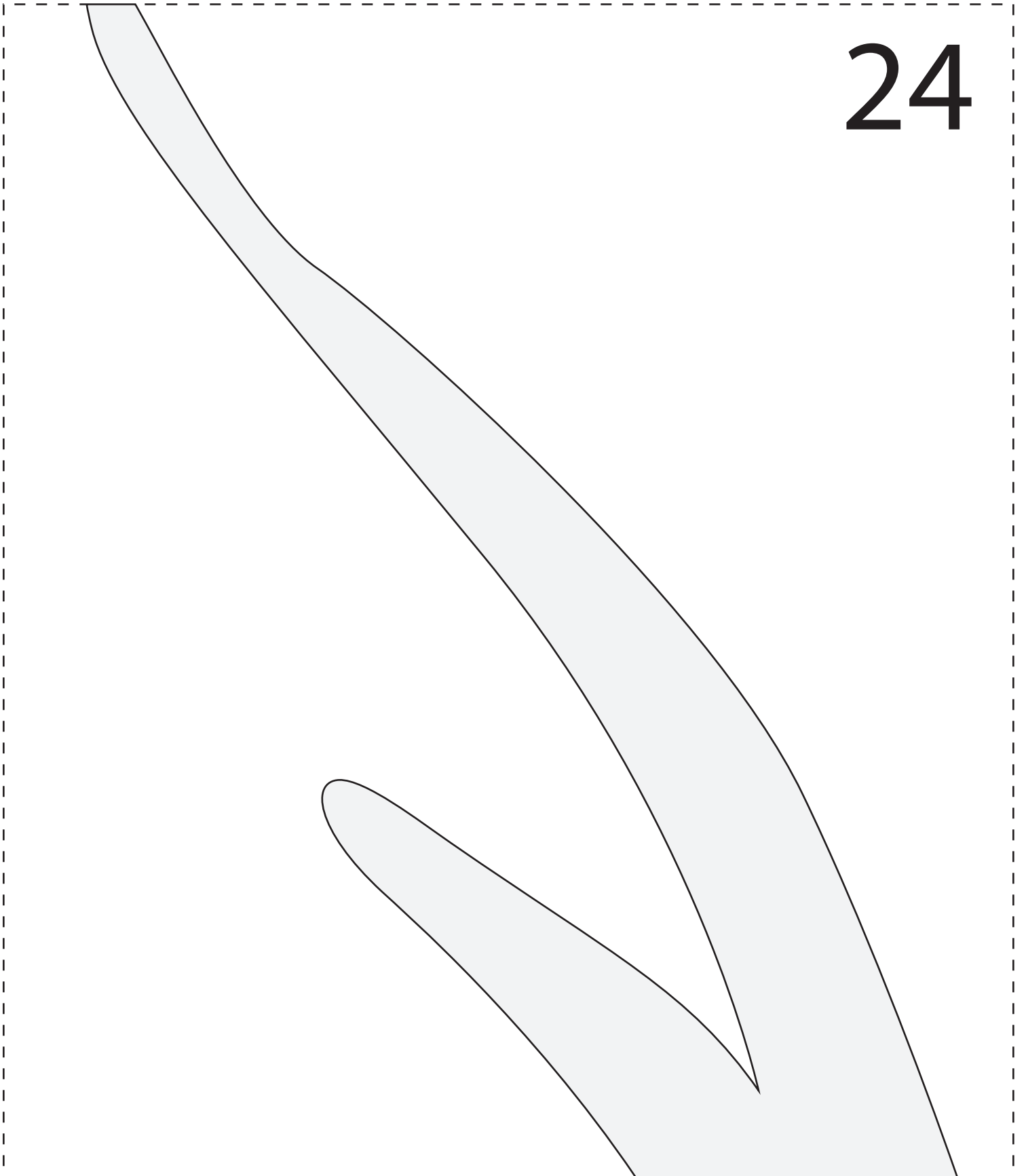



# In Motion

Template - 25

25

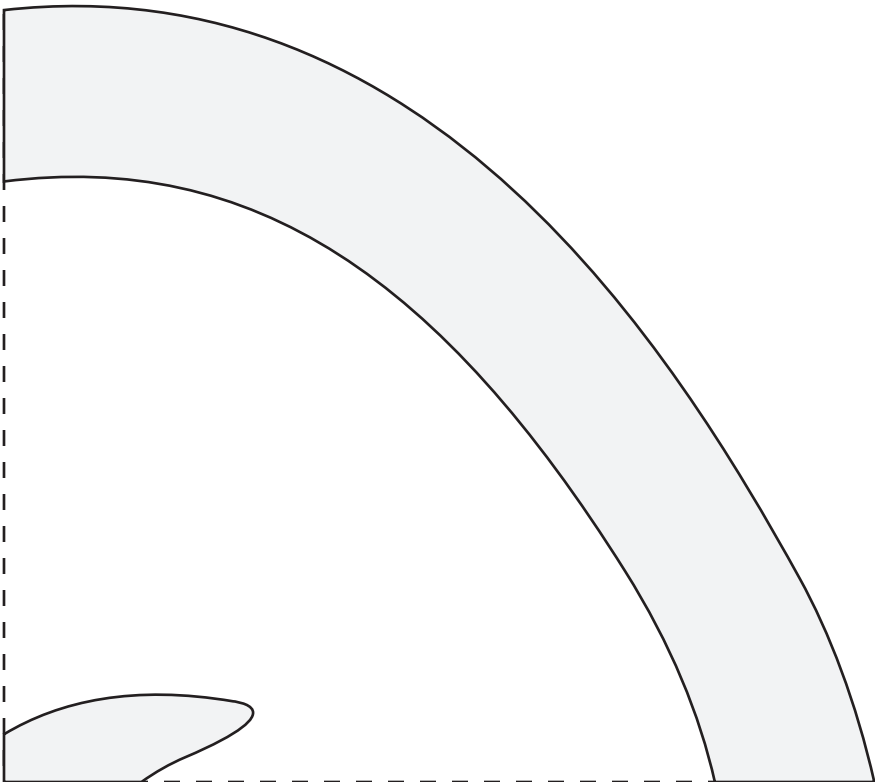



# In Motion

Template - 26

26

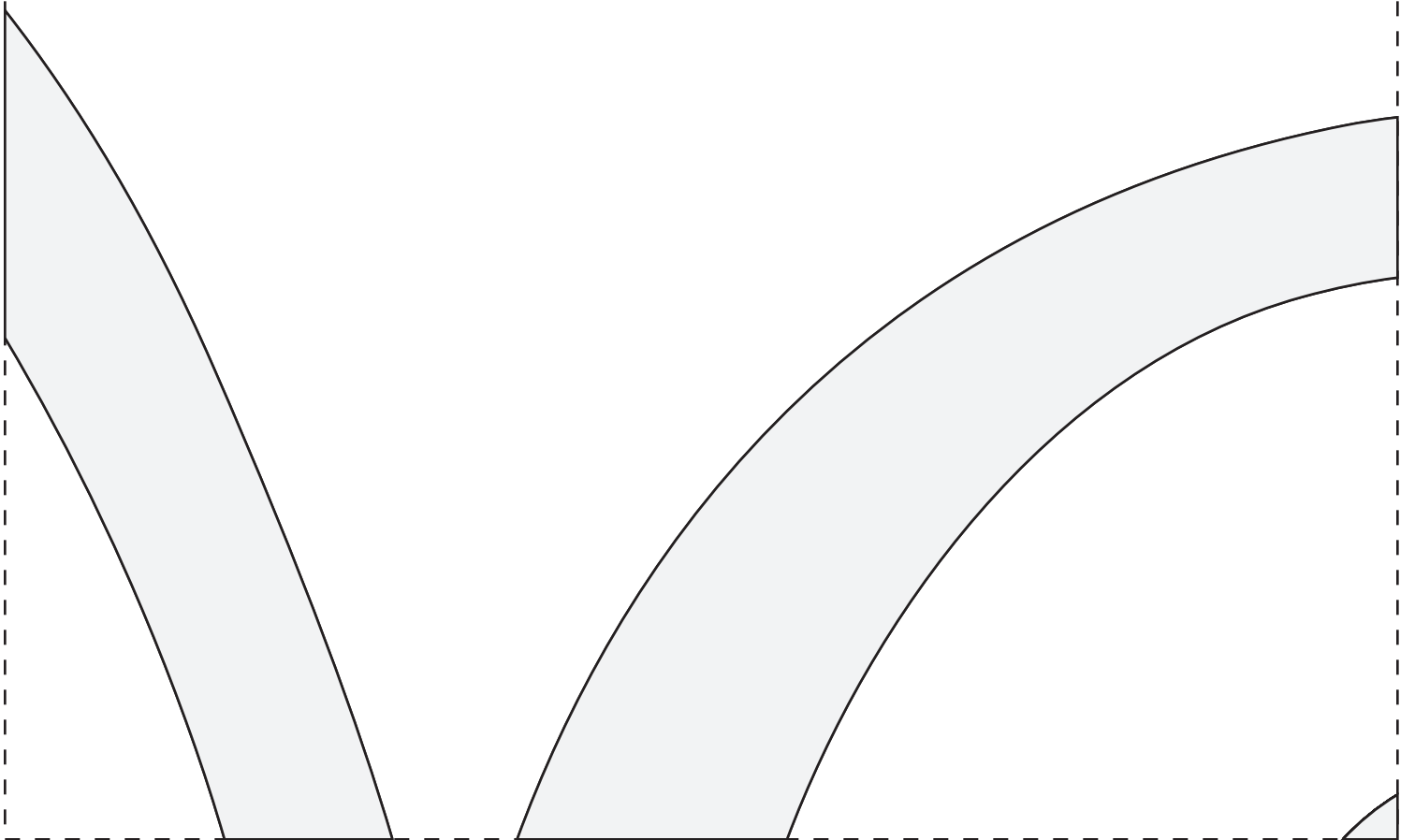



# In Motion

Template - 27

27

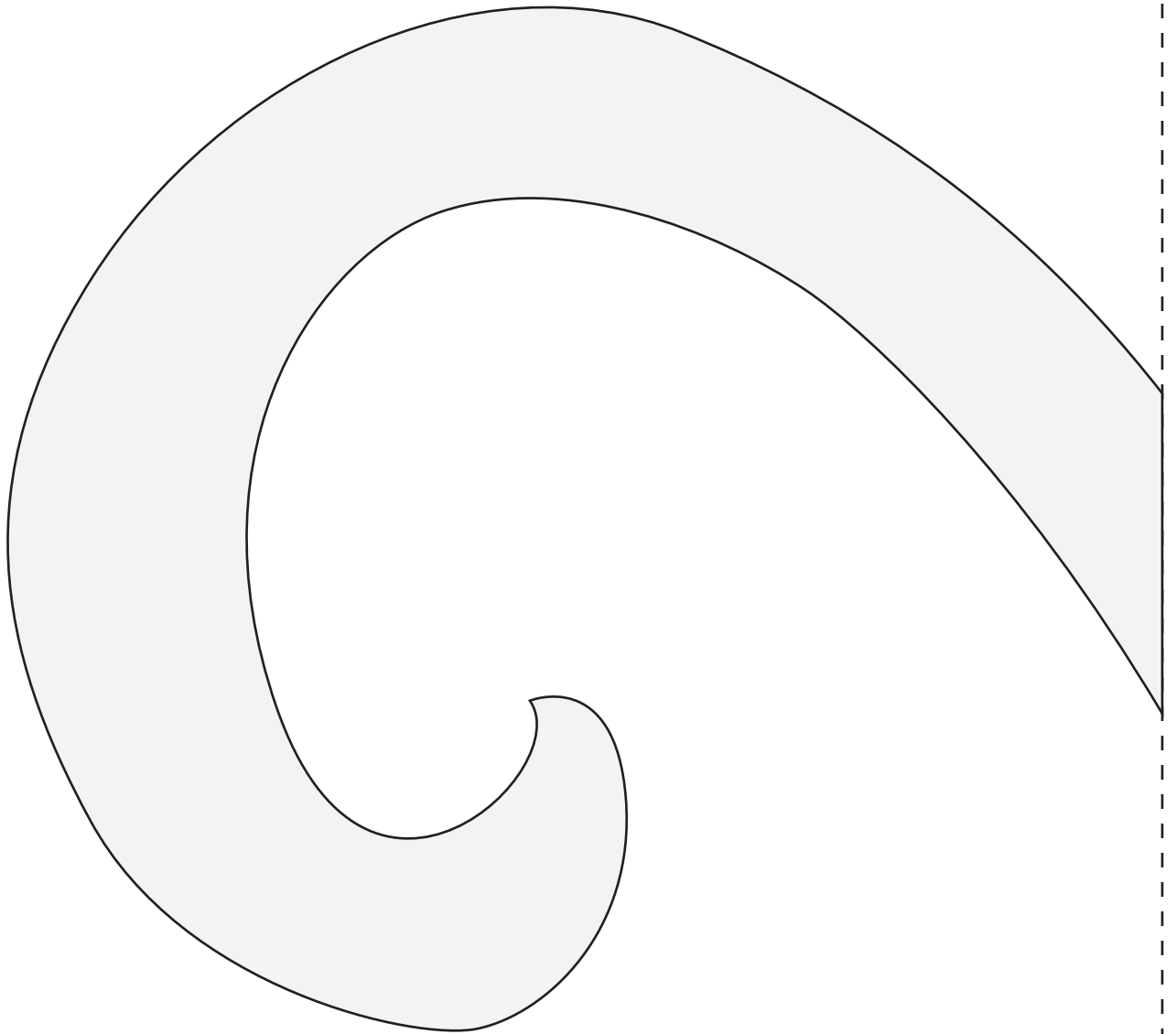



# In Motion

Template - 28

28

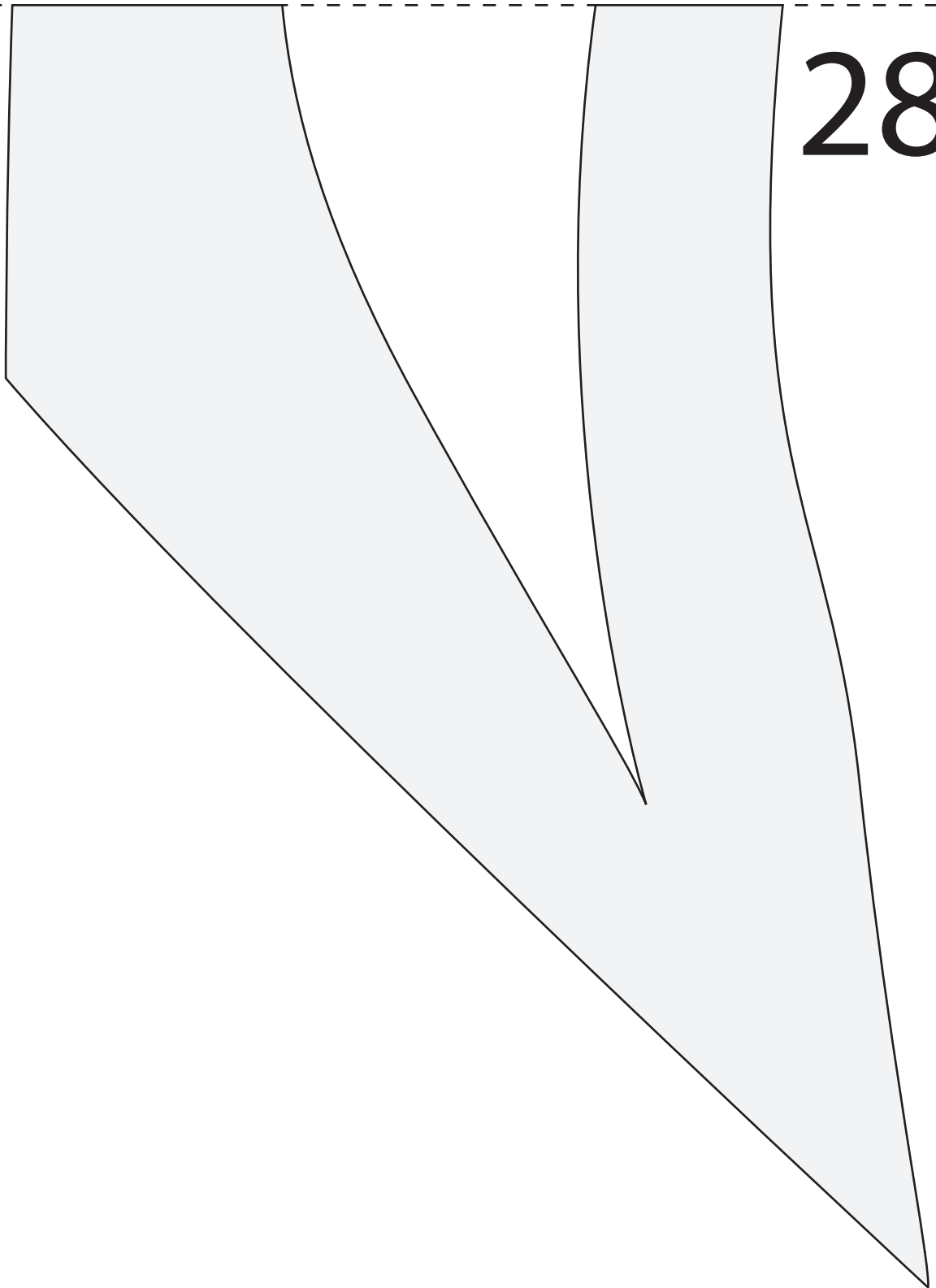



# In Motion

Template - 29

29

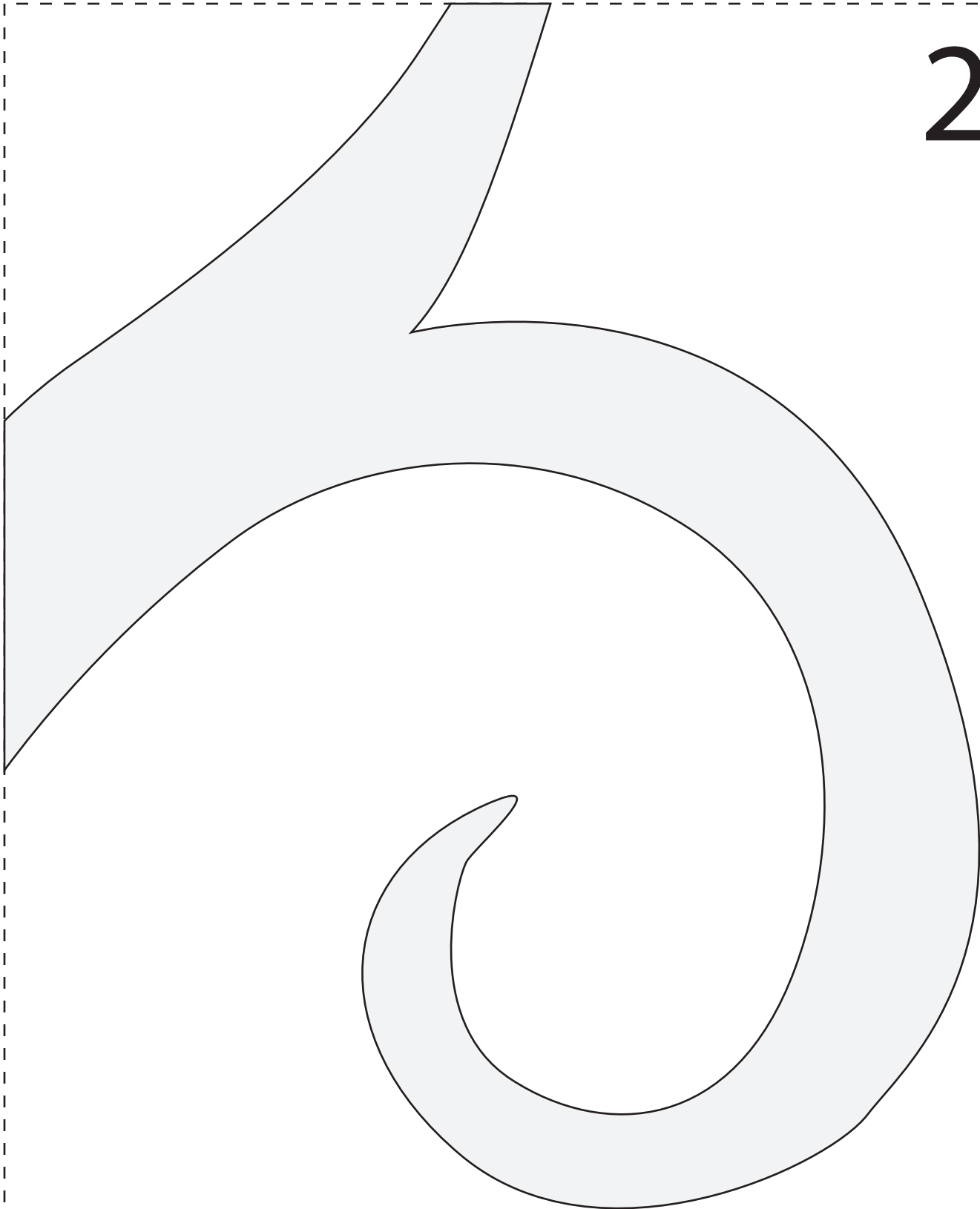



# In Motion

Template - 30

30

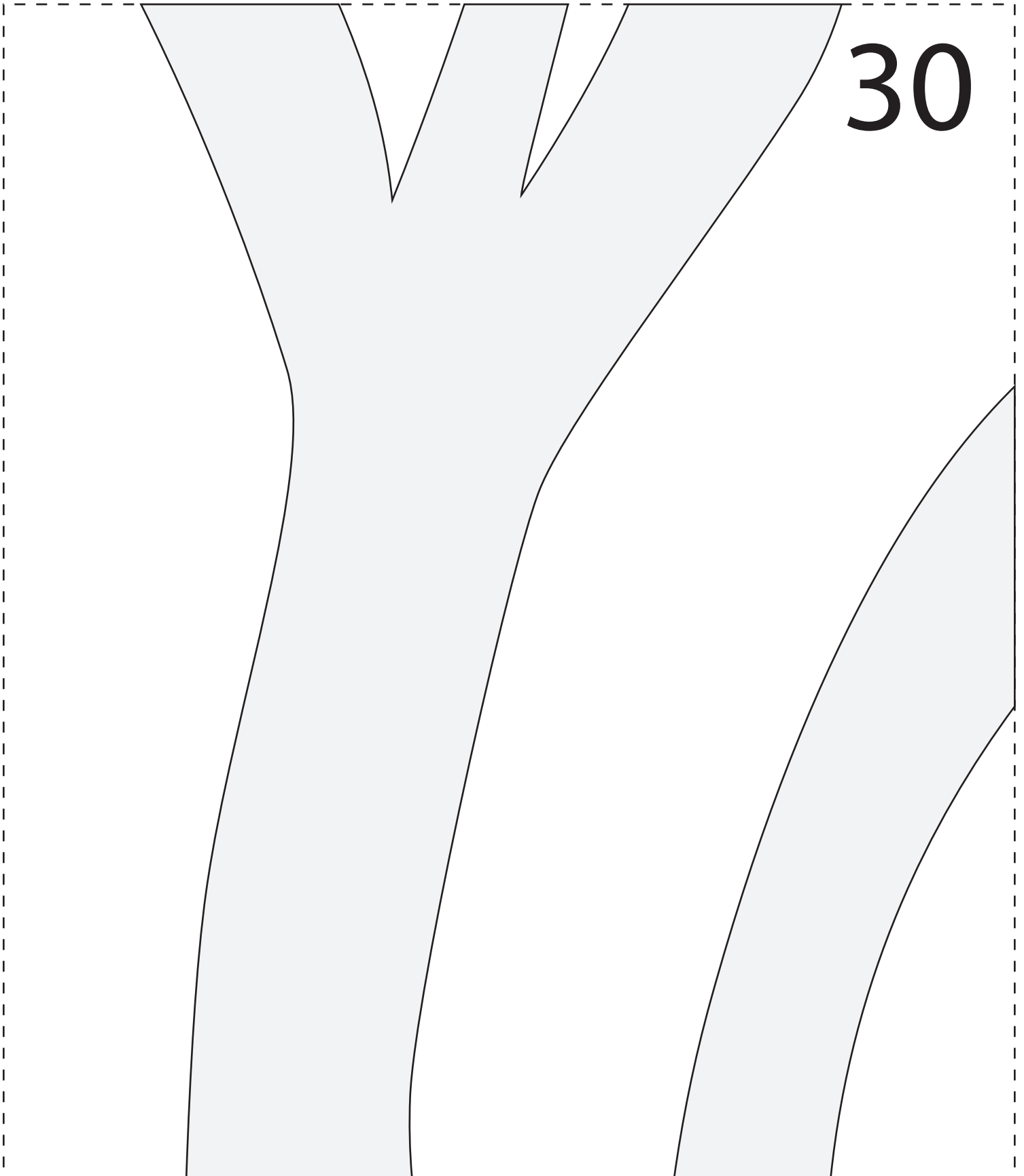



# In Motion

Template - 31

31

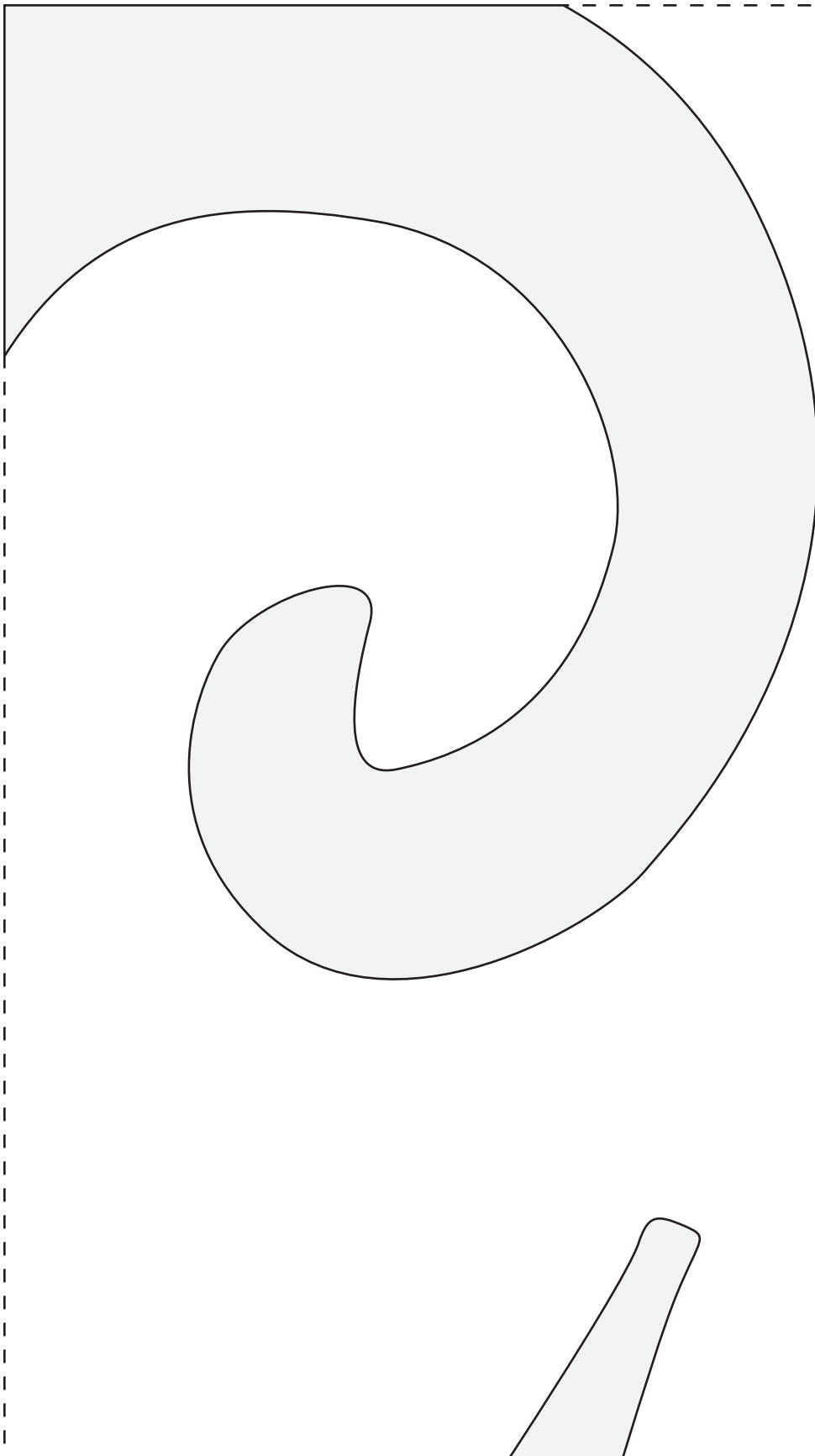





# In Motion

Template - 32

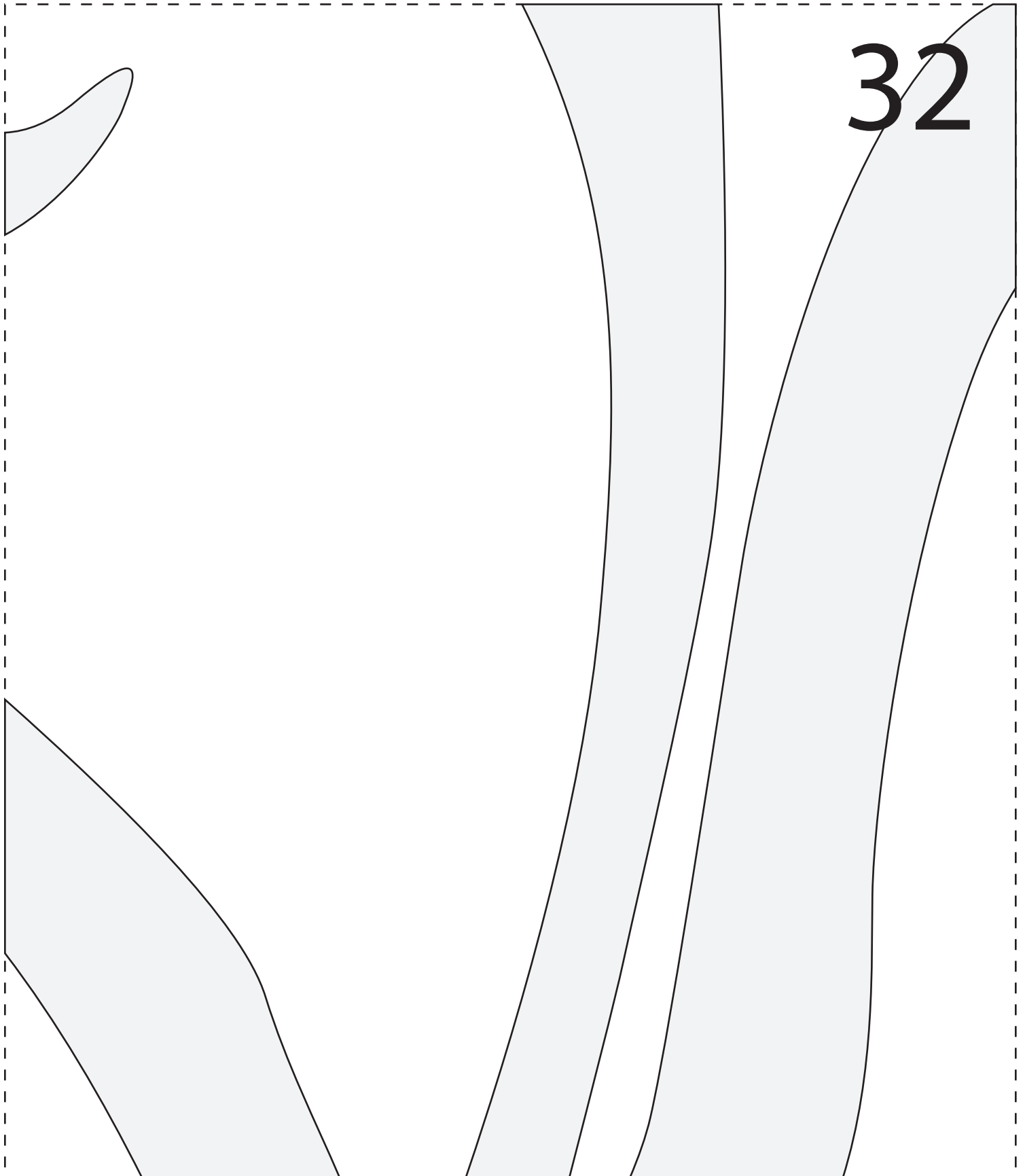



# In Motion

Template - 33

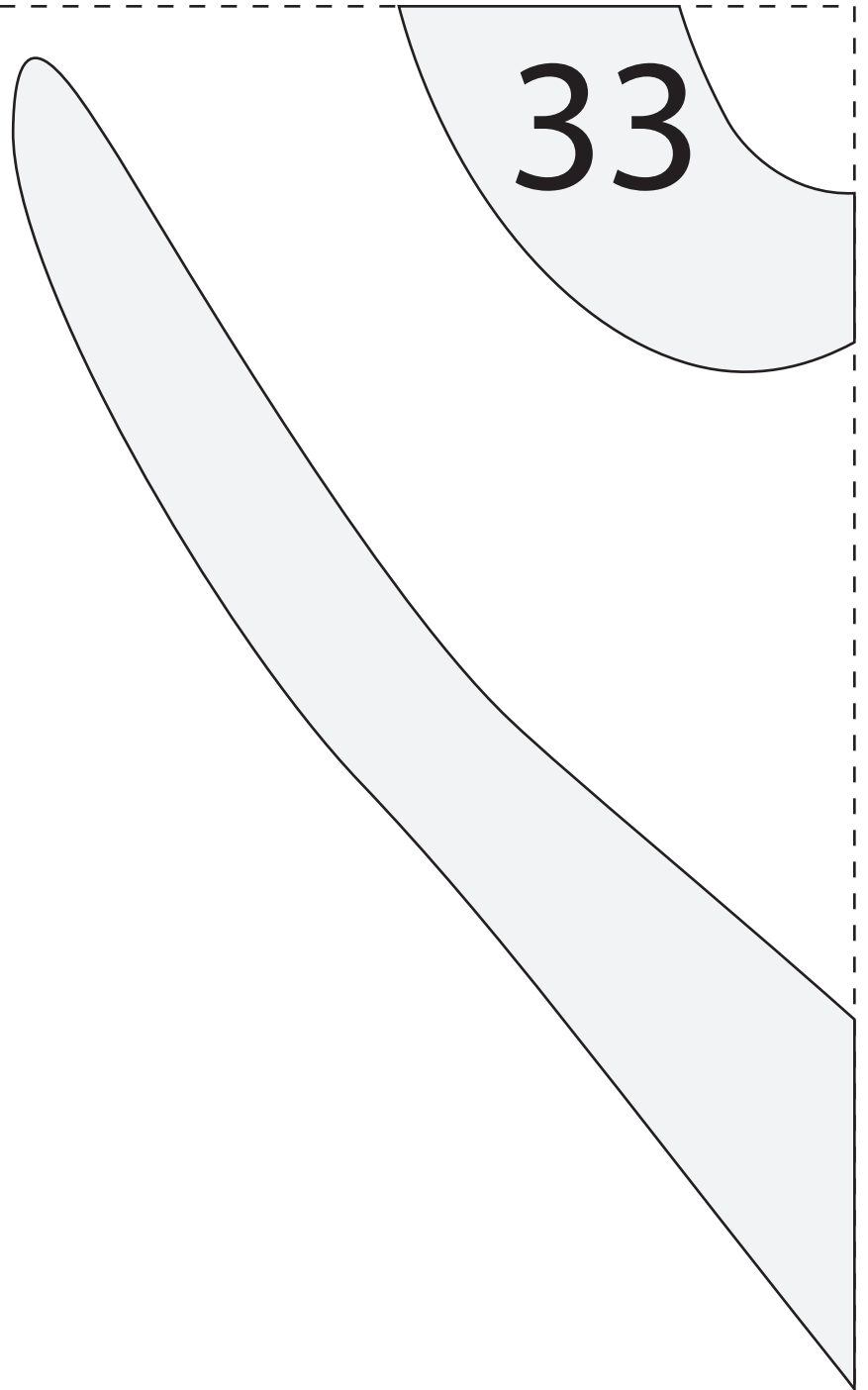



# In Motion

Template - 34

34





# In Motion

Template - 35

# 35

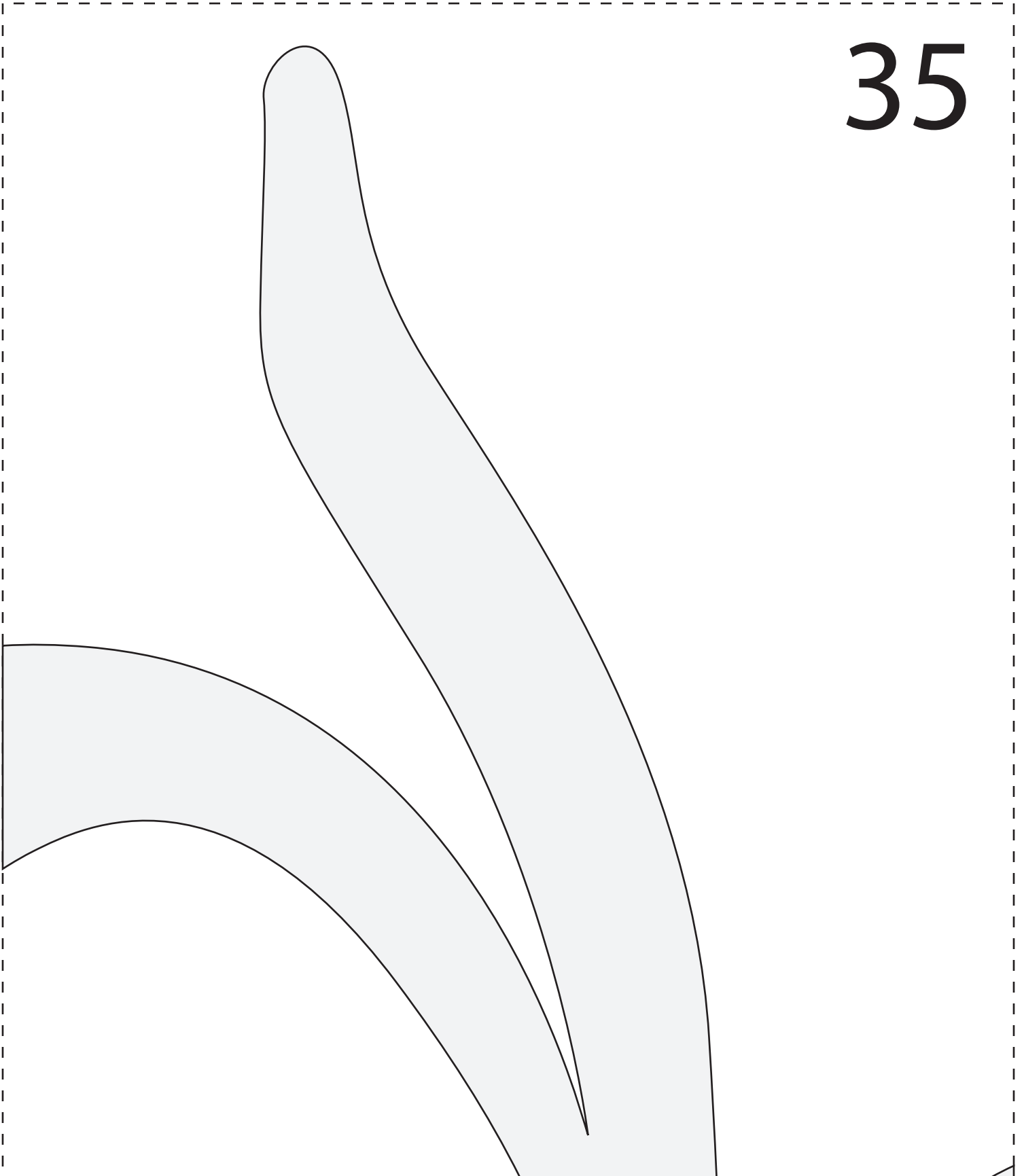



# In Motion

Template - 36

36

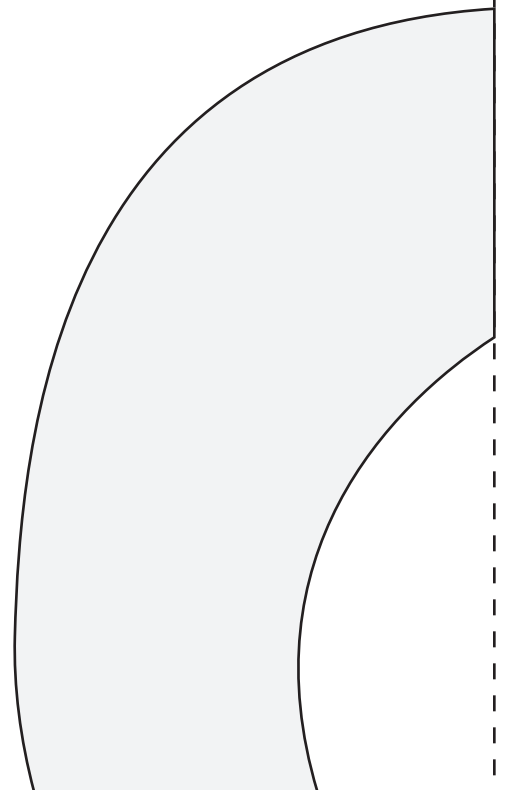



# In Motion

Template - 37

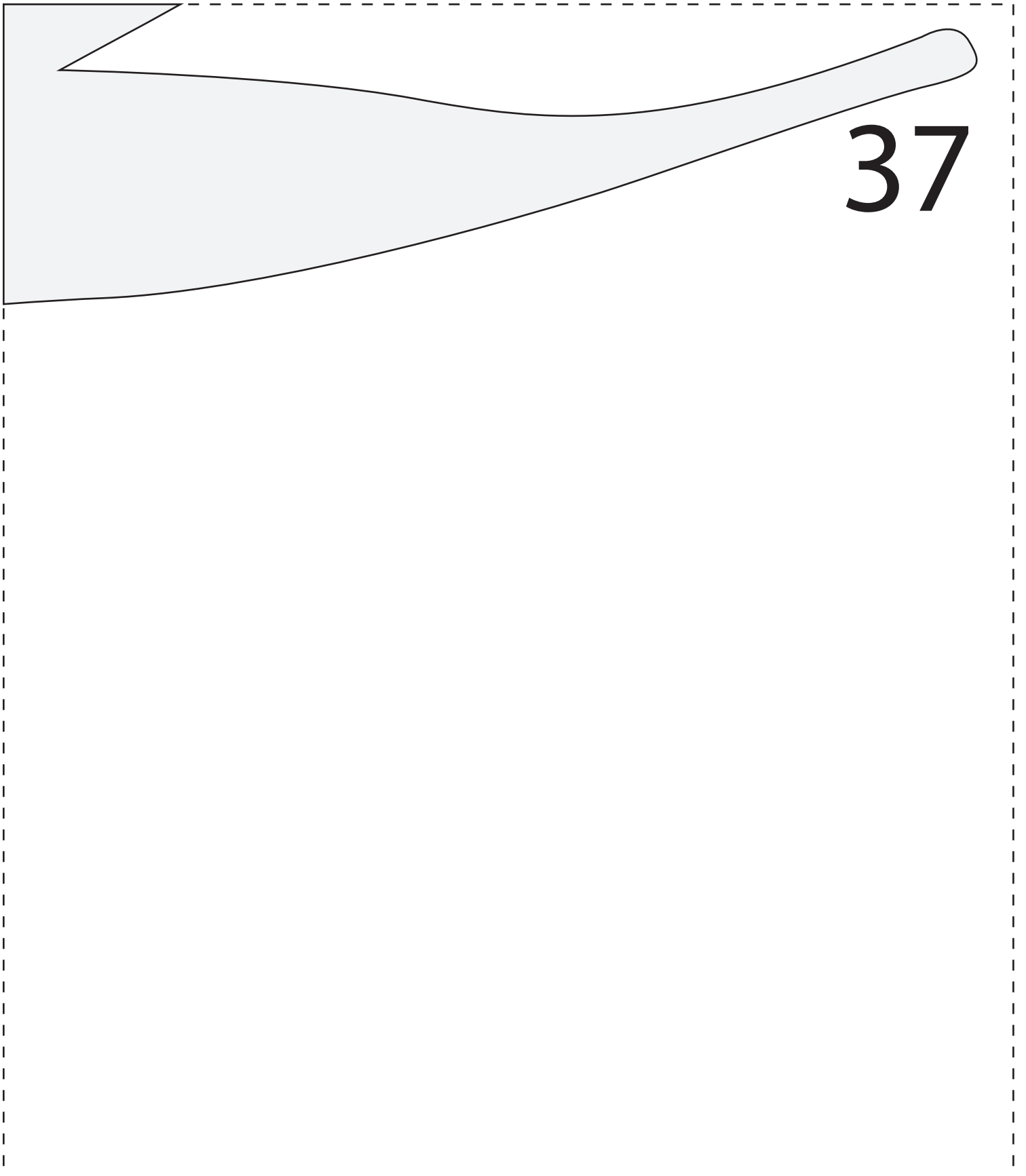



# In Motion

Template - 38

38

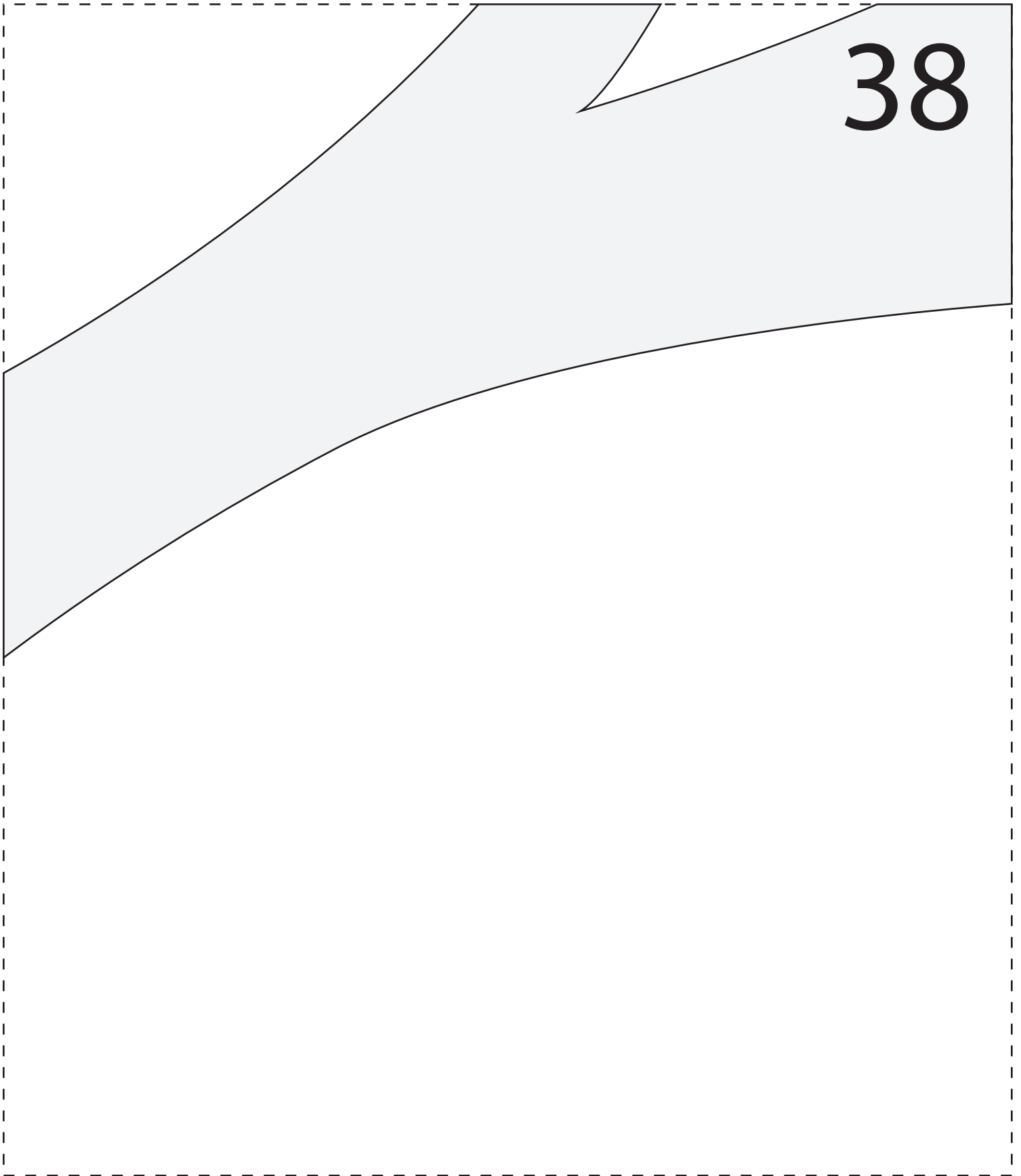



# In Motion

Template - 39

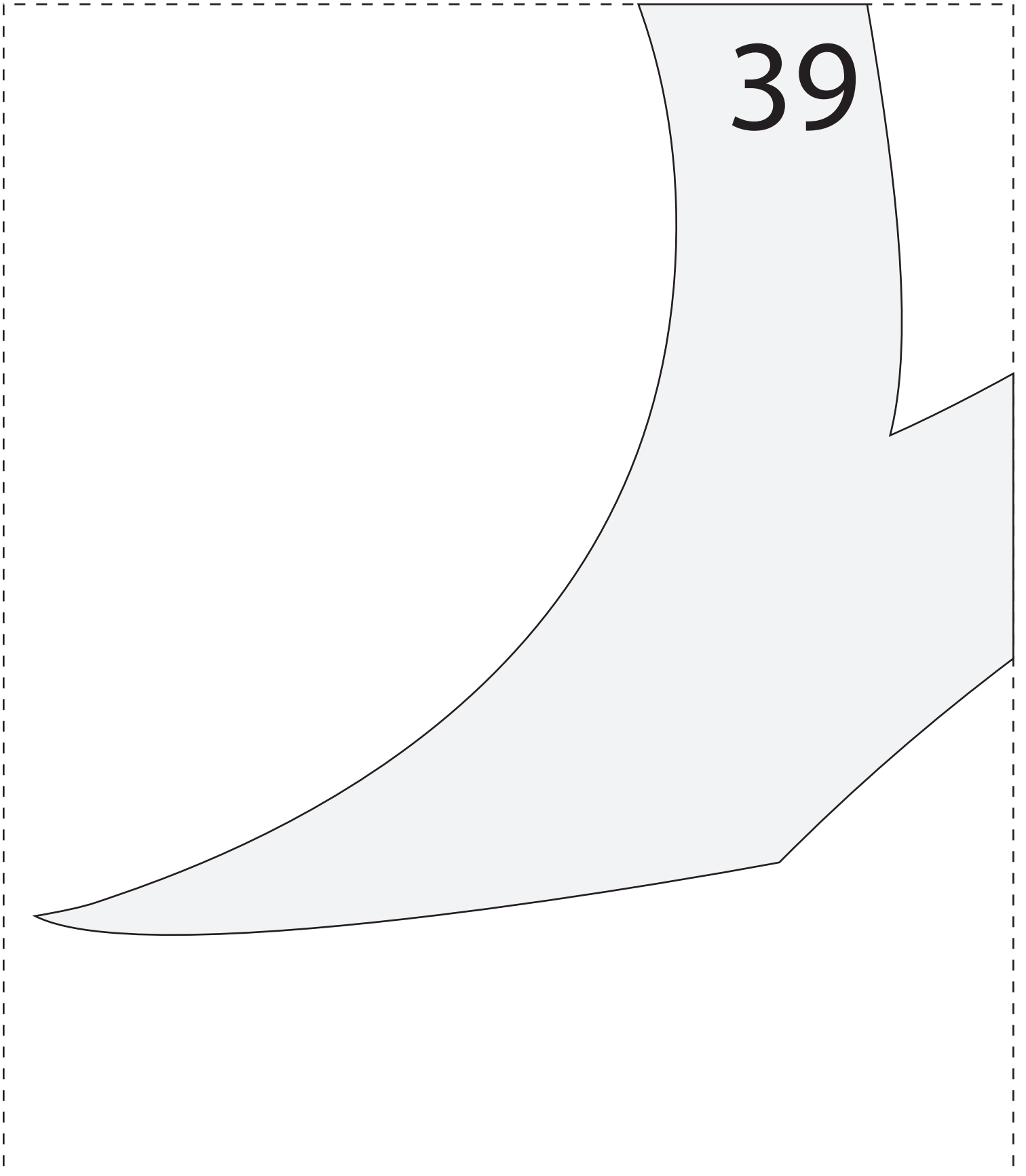





# In Motion

Template - 40

40

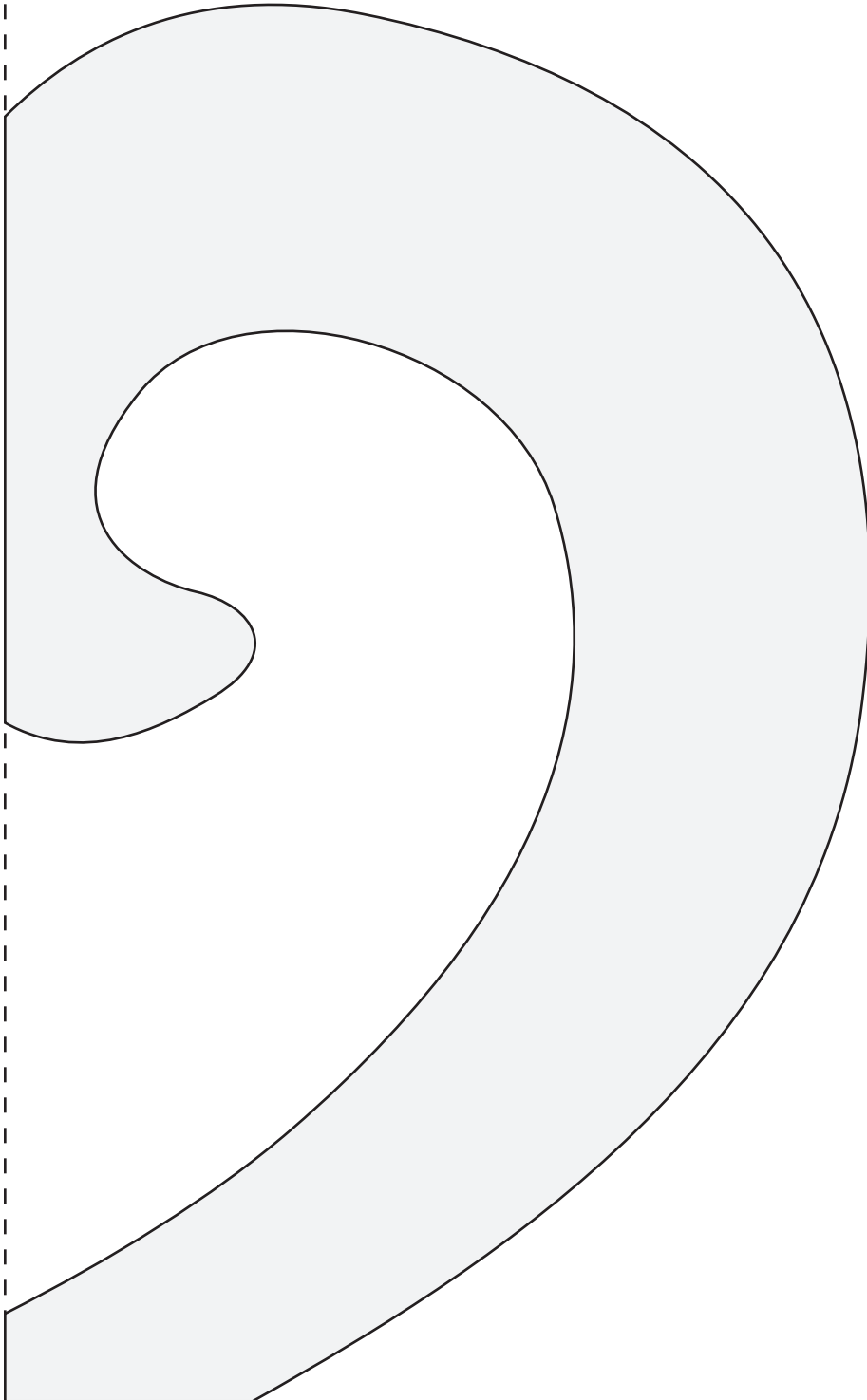



# In Motion

Template - 41

41

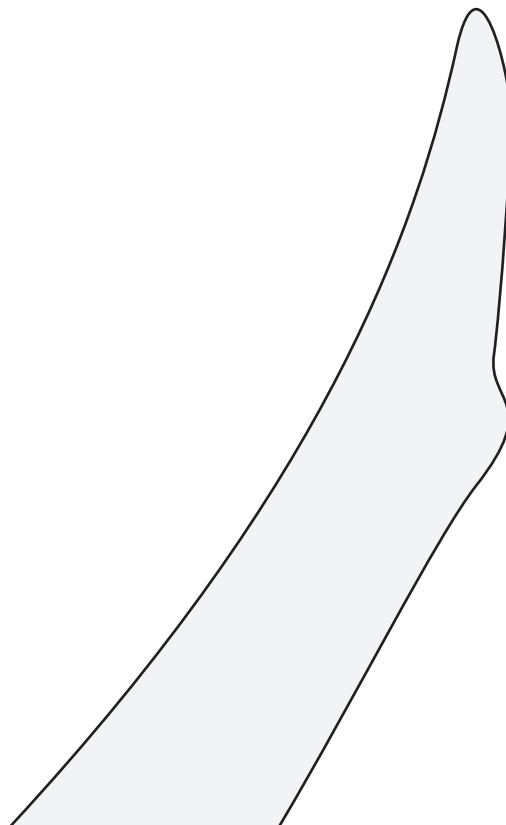
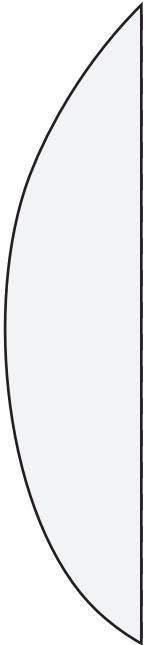
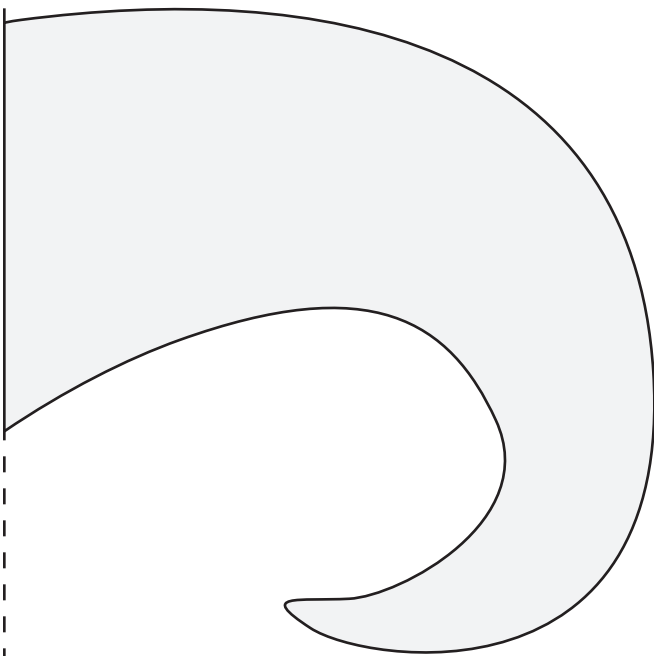



# In Motion

Template - 42

42

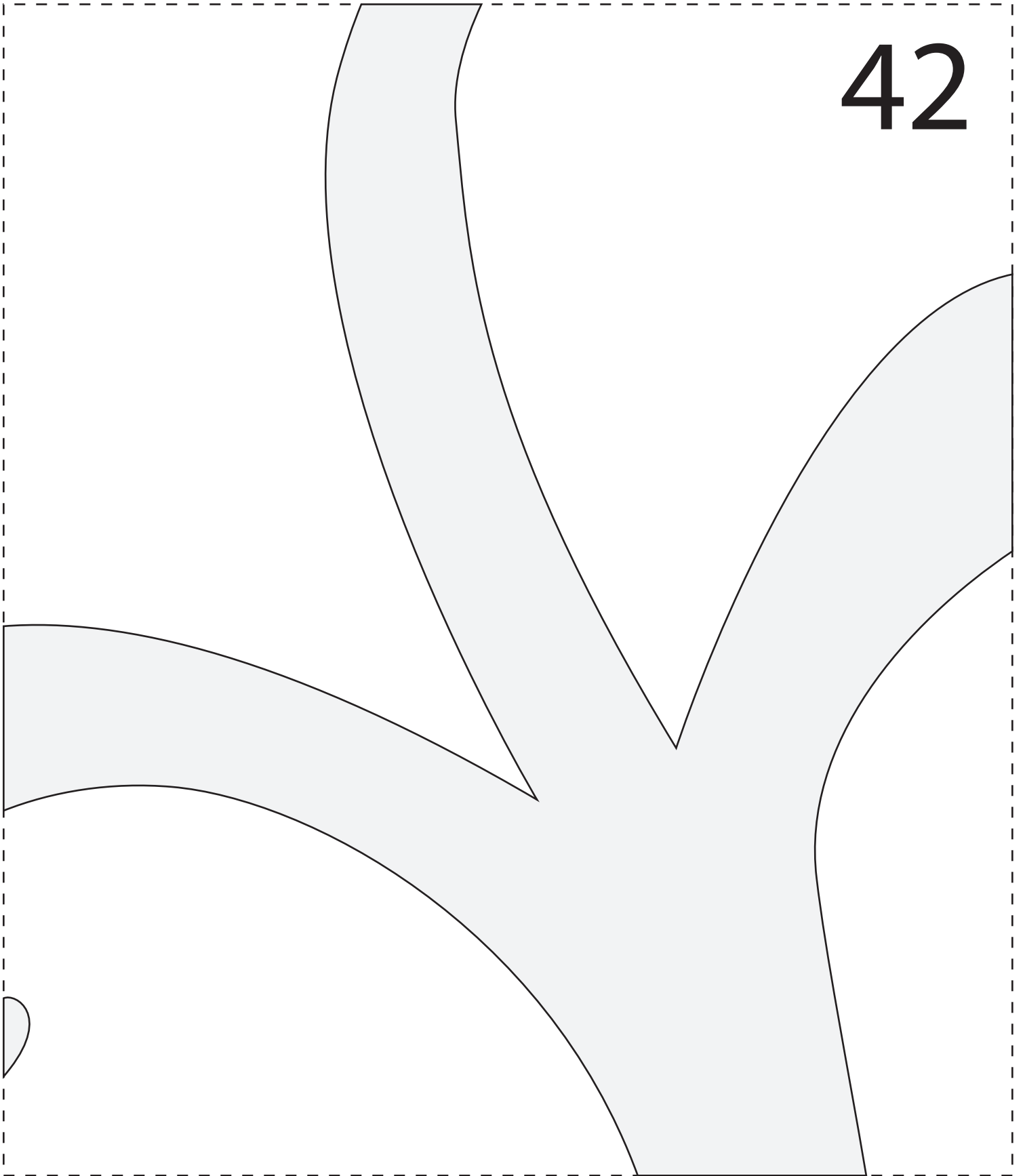



# In Motion

Template - 43

43

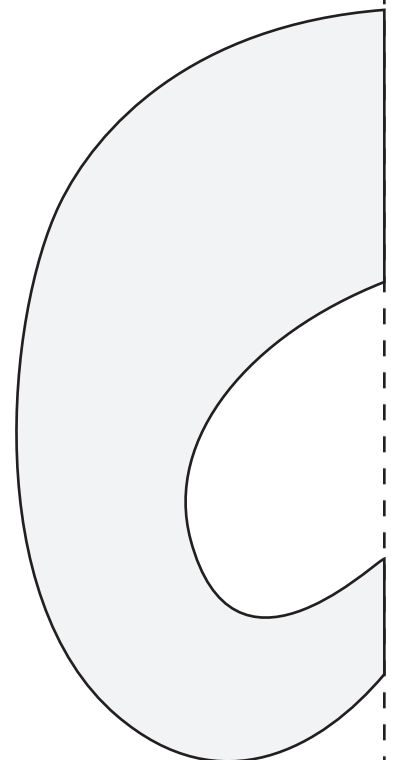



# In Motion

Template - 44

44

